



an EnPro Industries company

# QR-25<sup>®</sup> Series Model 5120

Parts Manual  
Record of Change 106

This manual contains important safety information and should be made available to all personnel who operate and/or maintain this product. Carefully read this manual before attempting to operate or perform maintenance on this compressor.

*Fill Out & Return Warranty Registration Card Located Inside*

Manual No. 50221-106

January 2007 Edition

# INTRODUCTION

This manual provides information for the following QR-25 Series, Model 5120 (Record of Change 106) compressor versions:

- L Control Version L**  
head assembly with 4 unloader towers & a hydraulic unloader
  
- LS Control Version LS**  
head assembly with 4 unloader towers, a hydraulic unloader, & a pilot valve with a check valve assembly
  
- LVD Control Version LVD**  
head assembly with 4 unloader towers, a hydraulic unloader, & a pilot valve with a lockout & check valve

These compressors are aircooled, two stage, four cylinder, pressure lubricated compressors, with up to 200 PSI continuous pressure capability (*201 to 250 PSI intermittent pressure capability with proper configuration; consult factory*). The Model 5120 has a 6" low pressure piston bore and a 3.25" high pressure piston bore and a 3.25" high pressure bore x 4" stroke and can be run at 400-1040 RPM.

- Available options included in this manual:
- spin-on oil filter
  - hooded air filter
  - hooded air filter / silencer

# CHANGES

since previous printing dated October 2006:

Record of Change 106 involved a redesign of the oil pump.

# TABLE OF CONTENTS

Serial Number Identification .....	2
Ordering Replacement Parts .....	2
Quin-Cip Lubrication .....	2
Crankcase Lubricant Capacity .....	2
Crankcase Group .....	3
Crankshaft Group .....	4
Bearing Carrier Groups	
with oil filter .....	5-6
less oil filter .....	7-8
Connecting Rod & Piston Groups	
Low Pressure .....	9-10
High Pressure .....	11-12
Cylinder & Head Groups	
Control Versions L, LS, LVD .....	13-14
Head Assemblies	
Control Versions L, LS, LVD .....	15-22
Control Groups	
Version L .....	23
Version LS .....	24-25
Version LVD .....	26-27
Shroud Group .....	28
Pilot Valves .....	29
Pilot Valve Repair Kit .....	29
Differential Setting Charts .....	29
Suction Valve Unloader Assemblies .....	30
Gasket Set .....	31
Kits .....	31
Recommended Spare Parts .....	31
Basic Compressor Repair Kit .....	31
Decals .....	31
Typical Unit Repair Parts List .....	32

# MODEL & SERIAL NUMBER IDENTIFICATION

Record  
of  
Change No.

The tag is a rectangular plate with a grid for 'MODEL' and 'SERIAL NO.', a 'Record of Change No.' field, and the Quincy Compressor logo and number '110831'.

**Model & Serial Number  
Identification Tag**

The model & serial number tag is located on the handhole plate side of the crankcase. Fill in the numbers from your compressor's tag in the corresponding spaces provided here and reference this page when ordering replacement parts.

All replacement parts are to be ordered through an authorized Quincy distributor. Insist on genuine Quincy parts only! Failure to do so may void warranty.

## ORDERING REPLACEMENT PARTS

Prompt service can be rendered on repair parts orders if the following information is given:

- Item 1)** the model number, record of change number, & serial number.
- Item 2)** the exact part number needed. (Do not order by item numbers.)
- Item 3)** the exact quantity needed.
- Item 4)** the preferred type of transportation

**WARNING !**

Do not operate this compressor without a totally enclosed belt guard or any other required safety equipment.

**DANGER !**

Air used for breathing or food processing must meet OSHA 1910.134 or FDA 21 CFR 178.3570 regulations. Failure to do so may cause severe injury or death.

## QUIN-CIP® LUBRICANT

Refer to the chart below to order QUIN-CIP lubricant from your local authorized Quincy distributor.

Package	Part No.	Description
Barrel	112541D032	55 gal., SAE 10W
Pail	112541P032	5 gal., SAE 10W
Gallon	112541G032	1 gal., SAE 10W
Gallon Case	112541X032	(4)-1 gal., SAE 10W
Quart	112541Q032	1 qt., SAE 10W
Quart Case	112541C032	(12)-1 qt., SAE 10W
<hr/>		
Barrel	112542D068	55 gal., SAE 20
Pail	112542P068	5 gal., SAE 20
Gallon	112542G068	1 gal., SAE 20
Gallon Case	112542X068	(4)-1 gal., SAE 20
Quart	112542Q068	1 qt., SAE 20
Quart Case	112542C068	(12)-1 qt., SAE 20
<hr/>		
Barrel	112543D100	55 gal., SAE 30
Pail	112543P100	5 gal., SAE 30
Gallon	112543G100	1 gal., SAE 30
Gallon Case	112543X100	(4)-1 gal., SAE 30
Quart	112543Q100	1 qt., SAE 30
Quart Case	112543C100	(12)-1 qt., SAE 30

## CRANKCASE LUBRICANT CAPACITY

Model	Less Filter	With Filter
QR-5120	9.75 Qts.	Add 10 oz.
	9.23 lit.	Add 296 ml

**CAUTION !**

Refer to the QR-25 Series Instruction Manual for vital lubrication information.

**CAUTION !**

Follow all safety precautions outlined in the QR-25 Series instruction manual.

# CRANKCASE GROUP 110460-002

Item Number	Qty.	Part Number	Description
1	1	6640	crankcase
2	1	4357	bearing cup
3	2	6678	gasket, inspection plate
4	1	6645-1	inspection plate
5	1	110174-2	inspection plate
6	1	111876-3	oil gauge assembly
7	1	2057	pipe plug, 1/2 npt
8	*	1498	bearing adjustment shim, .005 steel
9	*	1498A	bearing adjustment shim, .007 plastic
10	*	1498B	bearing adjustment shim, .020 steel
11	*	1498C	bearing adjustment shim, .002 steel
12	1	6643	adjustment plate
13	4	123478-N14	hex. screw, 1/2-13 unc x 1.25, grade 5 (@ 75 ft.-lbs.)
14	1	5518X1	breather assembly
14.1	1	5518	breather tube
14.2	1	111304	breather filter
14.3	1	6864	breather ball seat
14.4	1	5783	breather ball
14.5	1	110705-D15	roll pin, 1/8 x 1.12
15	1	6936	breather cap
16	20	110428N038	flatwasher, 3/8
17	20	123478-L12	hex. screw, 3/8-16 unc x 1.00, grade 5 (@ 12 ft.-lbs.)
18	1	112033-908	"o"ring, 3/32 wide x .82 o.d.

## Parts for use with diester or phosphate ester synthetic based lubricants

18	1	112033-908	"o"ring, 3/32 wide x .82 o.d.
----	---	------------	-------------------------------

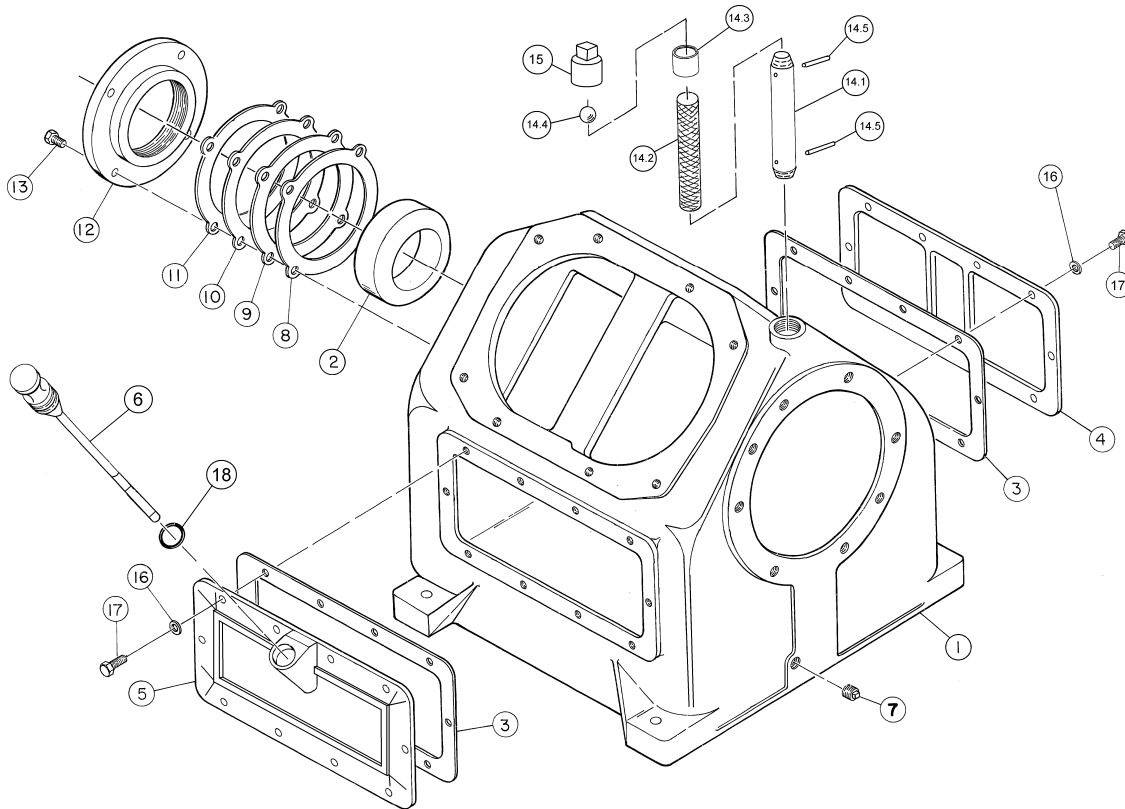

# CRANKSHAFT GROUP 110461

Item Number	Qty.	Part Number	Description
1	1	110227-001	crankshaft assembly
1.1	1	110226-001R	crankshaft (N.S.S.; order 110227-001)
1.2	1	6651	bearing cone
1.3	1	40775	bearing cone
1.4	3	2755S	pipe plug, 1/4 npt
1.5	1	110234	orifice, 1/8 npt
1.6	1	110705-F21	roll pin, 3/16 x 1.88
2	1	2851	key
3	1	110558X	sheave assembly
3.1	1	8297-1R	sheave, 23-1/2", 4G, B section, CCW (N.S.S.; order 110558X)
3.2	2	123478-Q21	hex. screw, 5/8-11 unc x 3.00, grade 5 ( @ 150 ft.-lbs.)
3.3	2	115512	flatwasher-5/8
3.4	2	123115-10C	lockwasher, 5/8
3.5	2	1883-001	square nut, 5/8-11 unc

@ Indicates torque value (dry threads). Tighten multiple bolts, capscrews & hex nuts in a criss-cross or alternating pattern. Bring each fastener to the recommended torque specification in even increments.

N.S.S. = Not Sold Separate

Note: For reversal of compressor rotation refer to QR-25 instruction manual.

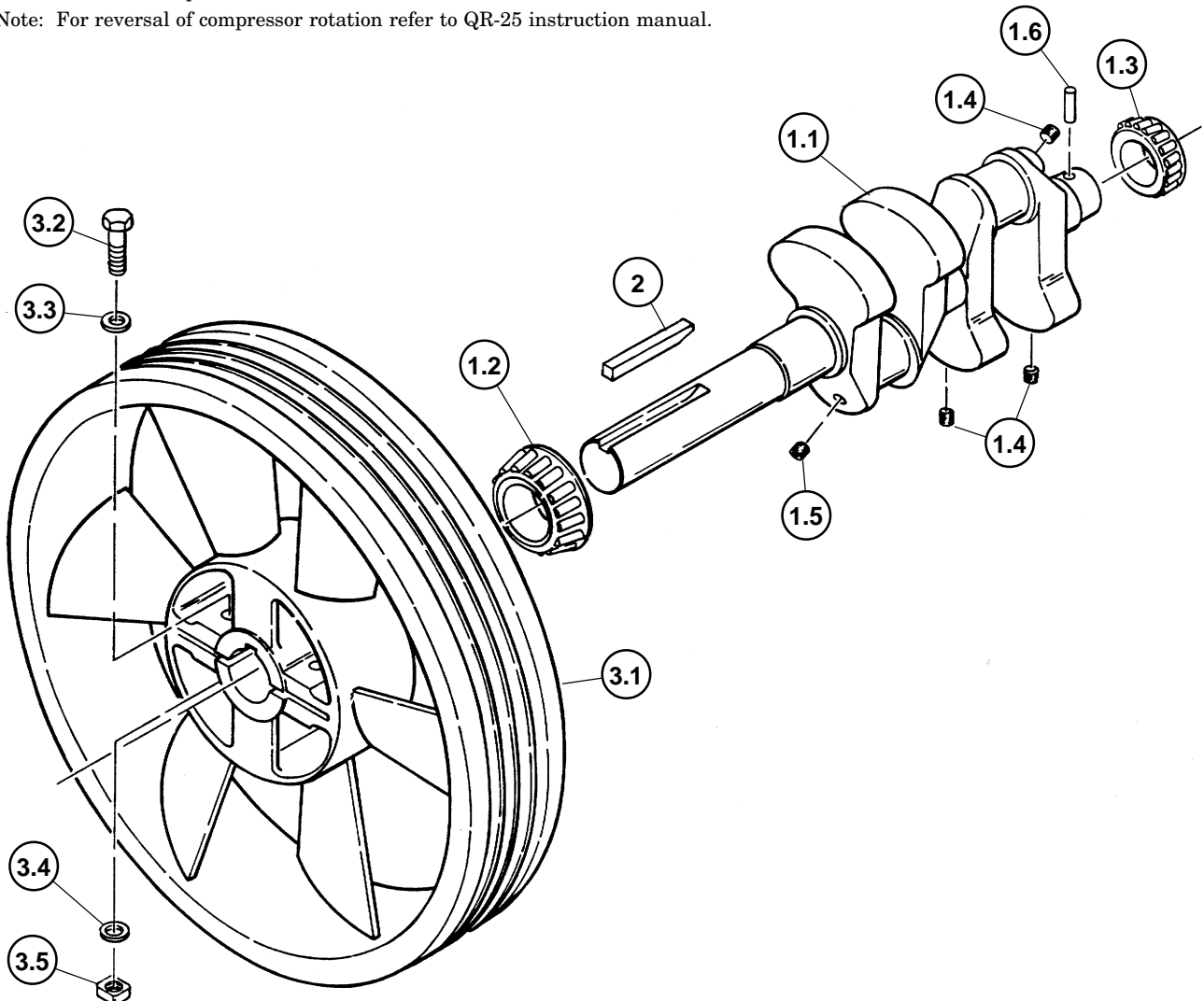

# BEARING CARRIER GROUP 110818-005

(with oil filter)

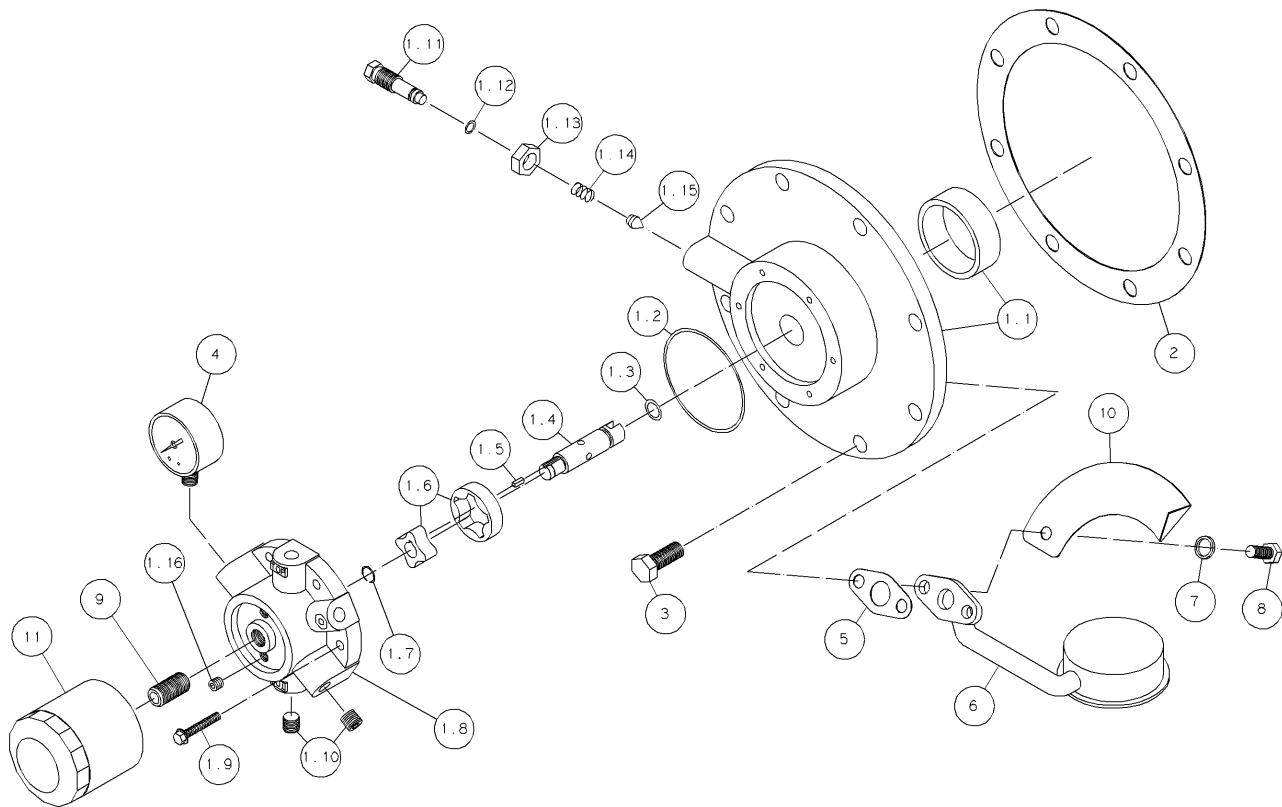

# BEARING CARRIER GROUP 1 10818-005

(with oil filter)

Item Number	Qty.	Part Number	Description
* 1	1	110811-007	bearing carrier assembly (N.S.S.; order 110811X007)
1.1	1	110811	bearing carrier (N.S.S.; order 110811X007)
	1	3720	bearing cup
	2	160005	bushing
* 1.2	1	123157-152	"o"ring, 3/32 wide x 3.44 o.d.
* 1.3	1	123157-112	"o"ring, 3/32 wide x .69 o.d.
1.4	1	160002-004	bearing carrier driveshaft
1.5	1	160075-001	driveshaft key
1.6	1	160003-1	pump gerotor
1.7	1	6285	retaining ring
1.8	1	110813-004	oil pump housing
1.9	6	123777-J12	hex. screw, 1/4-20 unc x 1.00, grade 5 (@ 6 ft.-lbs.)
§ 1.10	2	2719	pipe plug, 1/4 npt, hex socket
1.11	1	5489	adjustment screw
* 1.12	1	123157-011	"o"ring, 1/16 wide x .44 o.d.
1.13	1	124369-P02	jamnut, 9/16-18 unf
1.14	1	1160	spring
1.15	1	112857	needle valve
1.16	1	2755S	pipe plug, 1/8 npt
2	1	5494	gasket, bearing carrier
3	8	123478-N14	hex. screw, 1/2-13 unc x 1.25, grade 5 (@ 75 ft.-lbs.)
§ 4	1	110822	oil pressure gauge
5	1	6679	gasket
6	1	110660	oil pickup tube
7	2	123115-06C	lockwasher, 3/8
8	2	123478-L11	hex. screw, 3/8-16 unc x .88, grade 5 (@ 25 ft.-lbs.)
9	1	110825	stud
10	1	113159	oil deflector
<b>Maintenance Parts</b>			
* 11	1	110814-001	6 pack of oil filters
		* <b>160079-002</b>	<b>Oil Pump Repair Kit</b> includes "o"rings, driveshaft, key, pump gerotor, & retaining ring
		* <b>110811X007</b>	<b>Replacement Bearing Carrier Assembly</b> includes bearing carrier assembly, oil filter, stud, & bearing carrier gaskets
<b>Parts for use with diester or phosphate ester synthetic based lubricants</b>			
1.2	1	22749-152	"o"ring, 3/32 wide x 3.44 o.d.
1.3	1	22749-112	"o"ring, 3/32 wide x .69 o.d.
1.12	1	22749-011	"o"ring, 1/16 wide x .44 o.d.
		<b>160079-003</b>	<b>Oil Pump Repair Kit</b> includes "o"rings, driveshaft, key, pump gerotor, & retaining ring

N.S.S. = Not Sold Separate

@ Indicates torque value (dry threads). Tighten multiple bolts, capscrews & hex nuts in a criss-cross or alternating pattern. Bring each fastener to the recommended torque specification in even increments.

\* Can not be used with diester or phosphate ester synthetic lubricants.

§ Install with Teflon® tape.

# BEARING CARRIER GROUP 110818-006

(less oil filter)

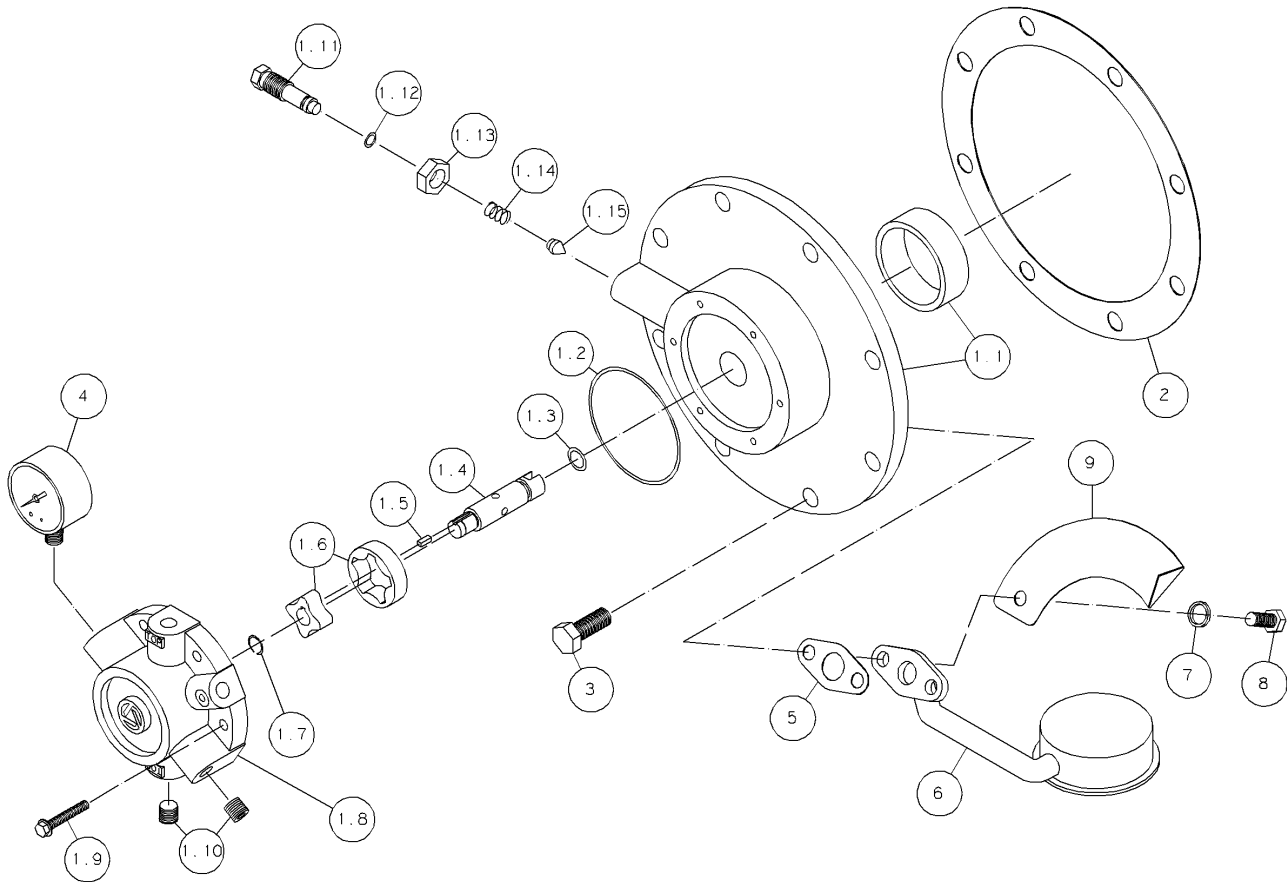

# BEARING CARRIER GROUP 110818-006

(less oil filter)

Item Number	Qty.	Part Number	Description
* 1	1	110811-008	bearing carrier assembly (N.S.S.; order 110811X008)
1.1	1	110811	bearing carrier (N.S.S.; order 110811X008)
	1	3720	bearing cup
	2	160005	bushing
* 1.2	1	123157-152	"o"ring, 3/32 wide x 3.44 o.d.
* 1.3	1	123157-112	"o"ring, 3/32 wide x .69 o.d.
1.4	1	160002-004	bearing carrier driveshaft
1.5	1	160075-001	driveshaft key
1.6	1	160003-1	pump gerotor
1.7	1	6285	retaining ring
1.8	1	110813-003	housing
1.9	6	123777-J12	hex. screw, 1/4-20 unc x 1.00, grade 5 (@ 6 ft.-lbs.)
§ 1.10	3	2719	pipe plug, 1/4 npt, hex socket
1.11	1	5489	adjustment screw
* 1.12	1	123157-011	"o"ring, 1/16 wide x .44 o.d.
1.13	1	124369-P02	jamnut, 9/16-18 unf
1.14	1	1160	spring
1.15	1	112857	needle valve
2	1	5494	gasket, bearing carrier
3	8	123478-N14	hex. screw, 1/2-13 unc x 1.25, grade 5 (@ 75 ft.-lbs.)
§ 4	1	110822	oil pressure gauge
5	1	6679	gasket
6	1	110660	oil pickup tube
7	2	123115-06C	lockwasher, 3/8
8	2	123478-L11	hex. screw, 3/8-16 unc x .88, grade 5 (@ 25 ft.-lbs.)
9	1	113159	oil deflector

## Maintenance Parts

* 160079-002	<b>Oil Pump Repair Kit</b>	includes "o"rings, driveshaft, key, pump gerotor, & retaining ring
110811X008	<b>Replacement Bearing Carrier Assembly</b>	includes bearing carrier assy., bearing carrier gasket, & oil inlet bracket gasket

## Parts for use with diester or phosphate ester synthetic based lubricants

1.2	1	22749-152	"o"ring, 3/32 wide x 3.44 o.d.
1.3	1	22749-112	"o"ring, 3/32 wide x .69 o.d.
1.12	1	22749-011	"o"ring, 1/16 wide x .44 o.d.
160079-003	<b>Oil Pump Repair Kit</b>	includes "o"rings, driveshaft, key, pump gerotor, & retaining ring	

N.S.S. = Not Sold Separate

@ Indicates torque value (dry threads). Tighten multiple bolts, capscrews & hex nuts in a criss-cross or alternating pattern. Bring each fastener to the recommended torque specification in even increments.

\* Can not be used with diester or phosphate ester synthetic lubricants.

§ Install with Teflon® tape.

# CONNECTING ROD & PISTON GROUP 110462

(low pressure)

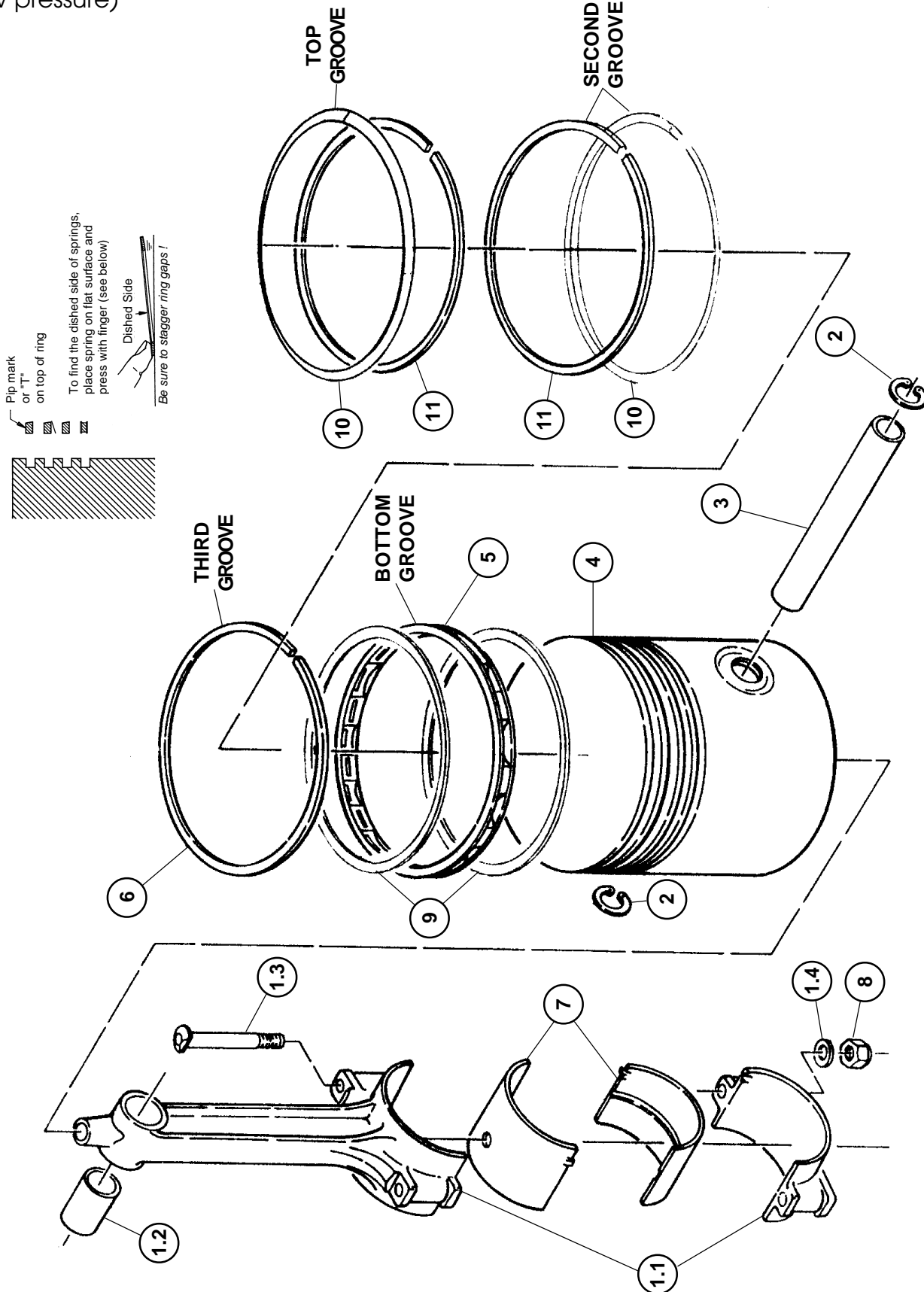

# CONNECTING ROD & PISTON GROUP 110462

(low pressure)

Item Number	Qty.	Part Number	Description
1	1	40081	connecting rod assembly (N.S.S.; order 6655X)
1.1	1	110803	connecting rod (N.S.S.; order 6655X)
1.2	1	6443	bushing, connecting rod (N.S.S.; order 6443SR)
1.3	2	1344	connecting rod bolt, 7/16-20 unc x 3.25
1.4	2	1319	connecting rod bolt washer
2	2	8648	retaining ring
3	1	8647	piston pin
4	1	8640	piston, LP
5	1	112749	ring spacer
6	1	9146	piston ring
7	2	6656	connecting rod insert (sold in pairs only; see maintenance parts)
8	2	124471-M08	locknut, 7/16-20 unf (@ 40 ft.-lbs.)
9	2	112748	oil ring rail
10	2	6994	spring
11	2	6992	piston ring
<b>Maintenance Parts</b>			
7	1	6656PR	connecting rod inserts (1 pair, standard size)
* 7	1	6656-010PR	connecting rod inserts (1 pair, .010 undersize)
* 4	1	8640-010	piston, LP (.010 oversize)
	1	<b>7527</b>	<b>Piston Ring Set, LP</b> includes piston rings, piston rails, piston spring, & spacer
	1	<b>5787-010</b>	<b>Piston Ring Set, LP</b> includes all rings necessary for installing .010 oversize piston
		<b>8640X</b>	<b>Piston Assembly, LP (Standard)</b> includes ring set, piston, piston pin, & retaining ring
		<b>8640X010</b>	<b>Piston Assembly, LP (.010 Oversize)</b> includes ring set, piston, piston pin, & retaining rings
		<b>6655X</b>	<b>Replacement Connecting Rod Assembly (Standard)</b> includes connecting rod assembly, connecting rod inserts, & locknuts
		<b>6655XUS</b>	<b>Replacement Connecting Rod Assembly (.010 Undersize)</b> includes connecting rod assembly, connecting rod inserts, & locknuts

@ Indicates torque value (dry threads). Tighten multiple bolts, capscrews & hex nuts in a criss-cross or alternating pattern. Bring each fastener to the recommended torque specification in even increments.

\* One pair required for each connecting rod assembly.

N.S.S. = Not Sold Separate

# CONNECTING ROD & PISTON GROUP 115811

(high pressure)

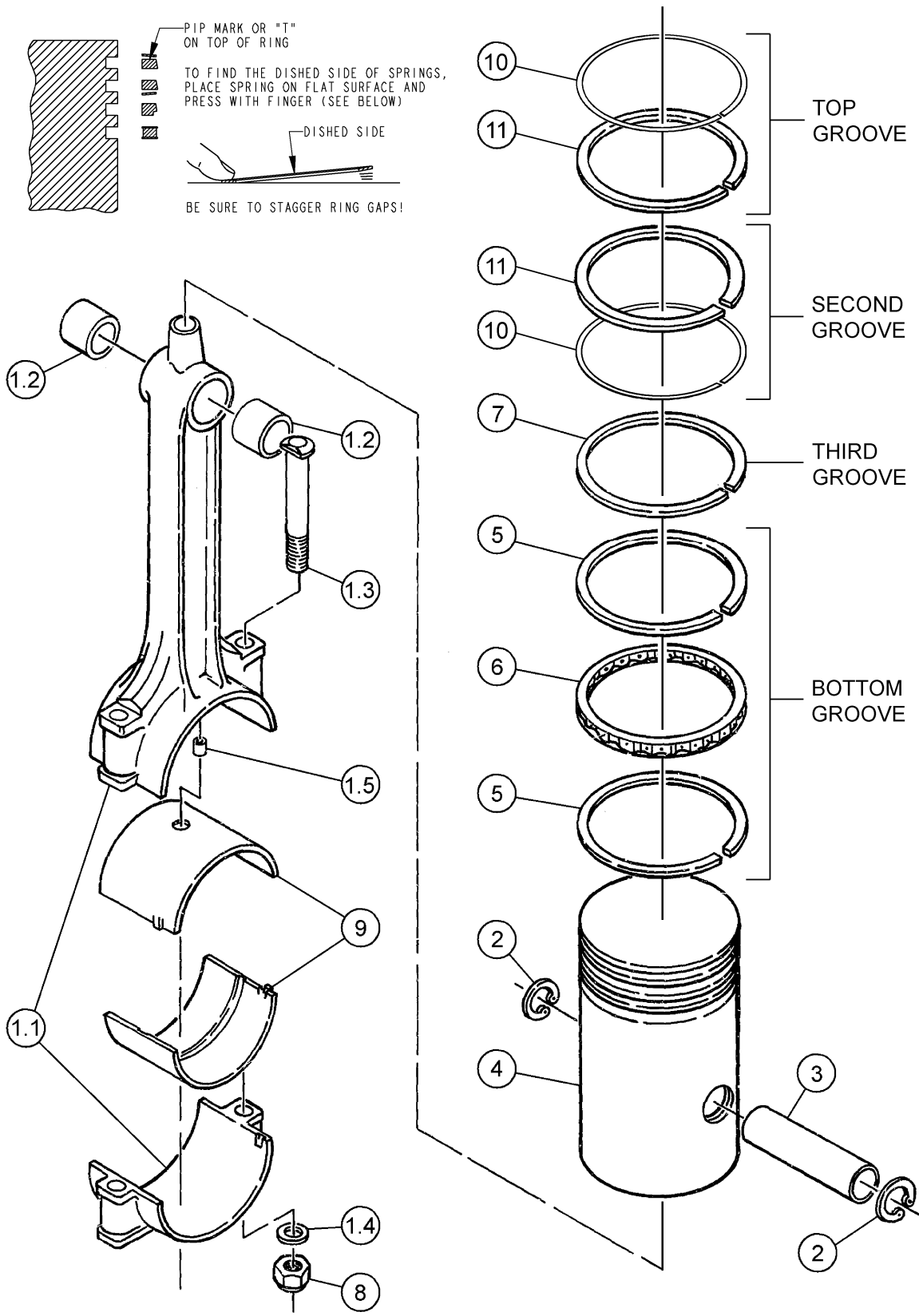

# CONNECTING ROD & PISTON GROUP 115811

(high pressure)

Item Number	Qty.	Part Number	Description
1	1	110804	connecting rod assembly (N.S.S.; order 110804X)
1.1	1	110802	connecting rod (N.S.S.; order 110804X)
1.2	2	110799-010	needle bearing
1.3	2	1344	connecting rod bolt, 7/16-20 unc x 3.25
1.4	2	1319	connecting rod bolt washer
1.5	1	110801-001	pipe plug orifice
2	2	8648	retaining ring
3	1	110190-004	piston pin
4	1	5846-001	piston, HP
5	2	112782	oil ring rail
6	1	112783	ring spacer
7	1	6997	piston ring
8	2	124471-M08	locknut, 7/16-20 unf (@ 40 ft.-lbs.)
9	2	6656	connecting rod insert (sold in pairs only; see maintenance parts)
10	2	7968	piston spring
11	2	7963	piston ring
<b>Maintenance Parts</b>			
* 9	1	6656PR	connecting rod inserts (1 pair, standard size)
* 9	1	6656-010PR	connecting rod inserts (1 pair, .010 undersize)
4	1	5846-011	piston, hp (.010 oversize)
		<b>8168</b>	<b>Piston Ring Set, HP (Standard) No Color Code</b> includes piston rings, piston rails, piston spring, & spacer
		<b>5788-010</b>	<b>Piston Ring Set, HP (.010 Oversize) (L. Blue)</b> includes all rings necessary for installing .010 oversize piston
		<b>5846X001</b>	<b>Piston Assembly, HP (Standard w/ side sealer)</b> includes ring set, piston, piston pin, & retaining ring
		<b>5846X011</b>	<b>Piston Assembly, HP (.010 Oversize)</b> includes ring set, piston, piston pin, & retaining ring
		<b>110804X</b>	<b>Replacement Connecting Rod Assembly (Standard)</b> includes connecting rod assembly, connecting rod inserts, & locknuts
		<b>110804X010</b>	<b>Replacement Connecting Rod Assembly (.010 Undersize)</b> includes connecting rod assembly, connecting rod inserts, & locknuts

@ Indicates torque value (dry threads). Tighten multiple bolts, capscrews & hex nuts in a criss-cross or alternating pattern. Bring each fastener to the recommended torque specification in even increments.

\* One pair required for each connecting rod assembly.

N.S.S. = Not Sold Separate

# CYLINDER & HEAD GROUP 110465-001

(control versions L, LS, & LVD)

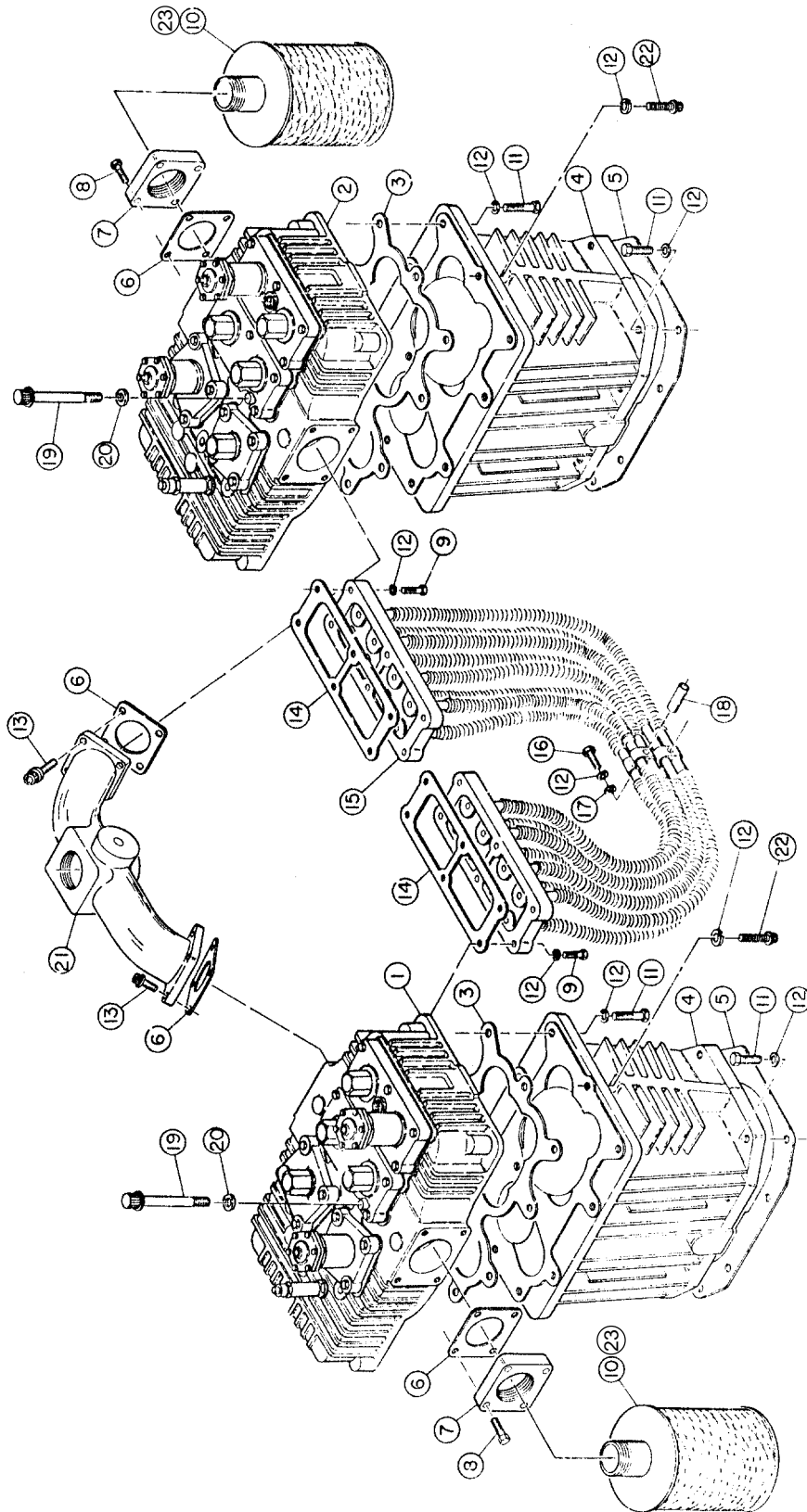

# CYLINDER & HEAD GROUP 110465-001

(control versions L, LS, & LVD)

Item Number	Qty.	Part Number	Description
1	1	7382UU	head assembly (see pages 21 & 23 for parts breakdown)
2	1	7383UU	head assembly (see pages 25 & 27 for parts breakdown)
3	2	7403	gasket, cylinder to head
4	2	7396-1	cylinder
5	2	5827	gasket, cylinder to crankcase
6	4	5828	gasket, companion flange
7	2	5858	intake flange
8	8	123478-M15	hex. screw, 7/16-14 unc x 1.50, grade 5 (@ 50 ft.-lbs.)
9	10	123478-N16	hex. screw, 1/2-13 unc x 1.75, grade 5 (@ 65 ft.-lbs.)
10	2	110377F200	air filter
	or		
10	2	110377H200	hooded air filter
	or		
10	2	110377S200	hooded air filter silencer
11	28	123478-N15	hex. screw, 1/2-13 unc x 1.50, grade 5 (@ 75 ft.-lbs.)
12	42	123115-08C	lockwasher, 1/2
13	8	90386-M14	counterbore screw, 7/16-14 unc x 1.25, grade 8 (@ 50 ft.-lbs.)
14	2	5860	gasket, intercooler to head
15	1	6658	intercooler
16	2	123478-N25	hex. screw, 1/2-13 unc x 4.00, grade 5 (@ 75 ft.-lbs.)
17	2	110428W050	flatwasher-1/2
18	2	6959	intercooler sleeve
19	12	5863	counterbore screw, 1/2-13 unc x 4.25, grade 8 (@ 65 ft.-lbs.)
20	12	1478-1	flatwasher
21	1	7445-002	discharge manifold
22	2	90386-N15	counterbore screw, 1/2-13 unc x 1.50, grade 8 (@ 50 ft.-lbs.)
			<b>Maintenance Parts</b>
23	2	110377E200	air filter element
	1	<b>7382X3L</b>	<b>Replacement Head Assembly</b> includes head assembly & gaskets
	1	<b>7383X3L</b>	<b>Replacement Head Assembly</b> includes head assy., gasket, fittings, & copper tubes

@ Indicates torque value (dry threads). Tighten multiple bolts, capscrews & hex nuts in a criss-cross or alternating pattern. Bring each fastener to the recommended torque specification in even increments.

# LEFT HEAD ASSEMBLY 7382UU

(control versions L, LS, & LVD)

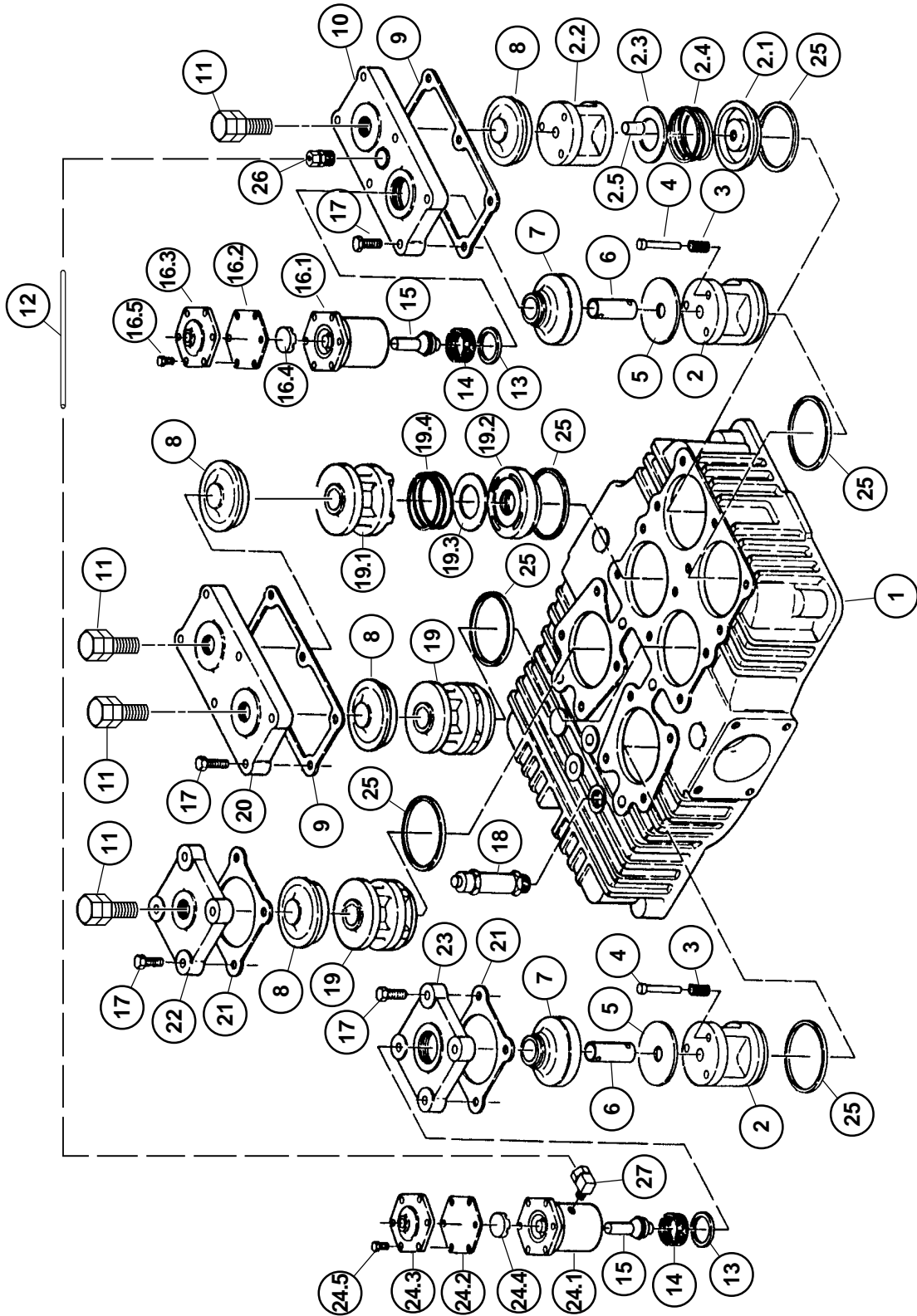

# \* LEFT HEAD ASSEMBLY 7382UU

(control versions L, LS, & LVD)

Item Number	Qty.	Part Number	Description
1	1	7382	head
2	3	6671X1	suction valve assembly
2.1	1	6671	valve bumper
2.2	1	2015	suction valve seat
2.3	1	2036	valve disc
2.4	1	6909	valve spring
2.5	1	1849	stud
3	6	6910	valve spring
4	6	1857	valve pin
5	2	5729	valve platform
6	2	6912-001	unloader pin
7	2	6911	valve retainer
8	4	6668-1R	valve retainer
9	2	7398	valve cover gasket
10	1	7385	valve cover plate
‡ 11	4	114545-R15	hex screw and nut assembly, 3/4-16 unf x 1.50, grade 5 (screw @ 60 ft.-lbs. - nut @ 50 ft.-lbs.)
12	2 ft.	110515-025	copper tube, 1/4 o.d.
13	2	1556	gasket, valve
14	2	3008	holddown screw/ (@ 60 ft.-lbs.)
15	2	7532X	unloader piston assembly
16	1	40192	unloader assembly (@ 75 ft.-lbs.), (N.S.S.; order 8272X)
16.1	1	8272	unloader body
16.2	1	1855	diaphragm
16.3	1	1818B	diaphragm cover plate
16.4	1	5910	diaphragm disc
16.5	6	7499	hex. screw, 1/4-20 unc x .75, grade 2 (@ 72 in.-lbs.)
‡ 17	20	7480	hex. screw, 7/16-14 unc x 1.38, grade 5 (@ 50 ft.-lbs.)
18	1	2961-100	pressure relief valve
19	3	6670X001	discharge valve assembly
19.1	1	6670-001	valve bumper
19.2	1	5812-001	valve seat
19.3	1	2036	valve disc
19.4	1	6909	valve spring
20	1	7384	cover plate
21	2	2025	valve cover gasket
22	1	6666	cover plate
23	1	6908	cover plate
24	1	40055	unloader assembly (@ 75 ft.-lbs.) (N.S.S.; order 7483X)
24.1	1	7483	unloader body
24.2	1	1855	diaphragm
24.3	1	1818B	diaphragm cover plate
24.4	1	5910	diaphragm disc
24.5	6	7499	hex. screw, 1/4-20 unc x .75, grade 2 (@ 72 in.-lbs.)
25	6	2024	valve gasket
26	1	110594-005	tube fitting, male connector, 1/4 tube x 1/4 npt
27	1	1642	tube fitting, 90° male elbow, 1/4 tube x 1/8 npt

continued on page 16

\* As viewed facing the compressor from the bearing carrier side.

‡ Tighten and torque valve cover plate screws (item 17) before tightening valve clamp screws (item 11).

@ Indicates torque value (dry threads). Tighten multiple bolts, capscrews & hex nuts in a criss-cross or alternating pattern. Bring each fastener to the recommended torque specification in even increments.

N.S.S. = Not Sold Separate

# LEFT HEAD ASSEMBLY 7382UU

(control versions L, LS, & LVD)

continued from page 15

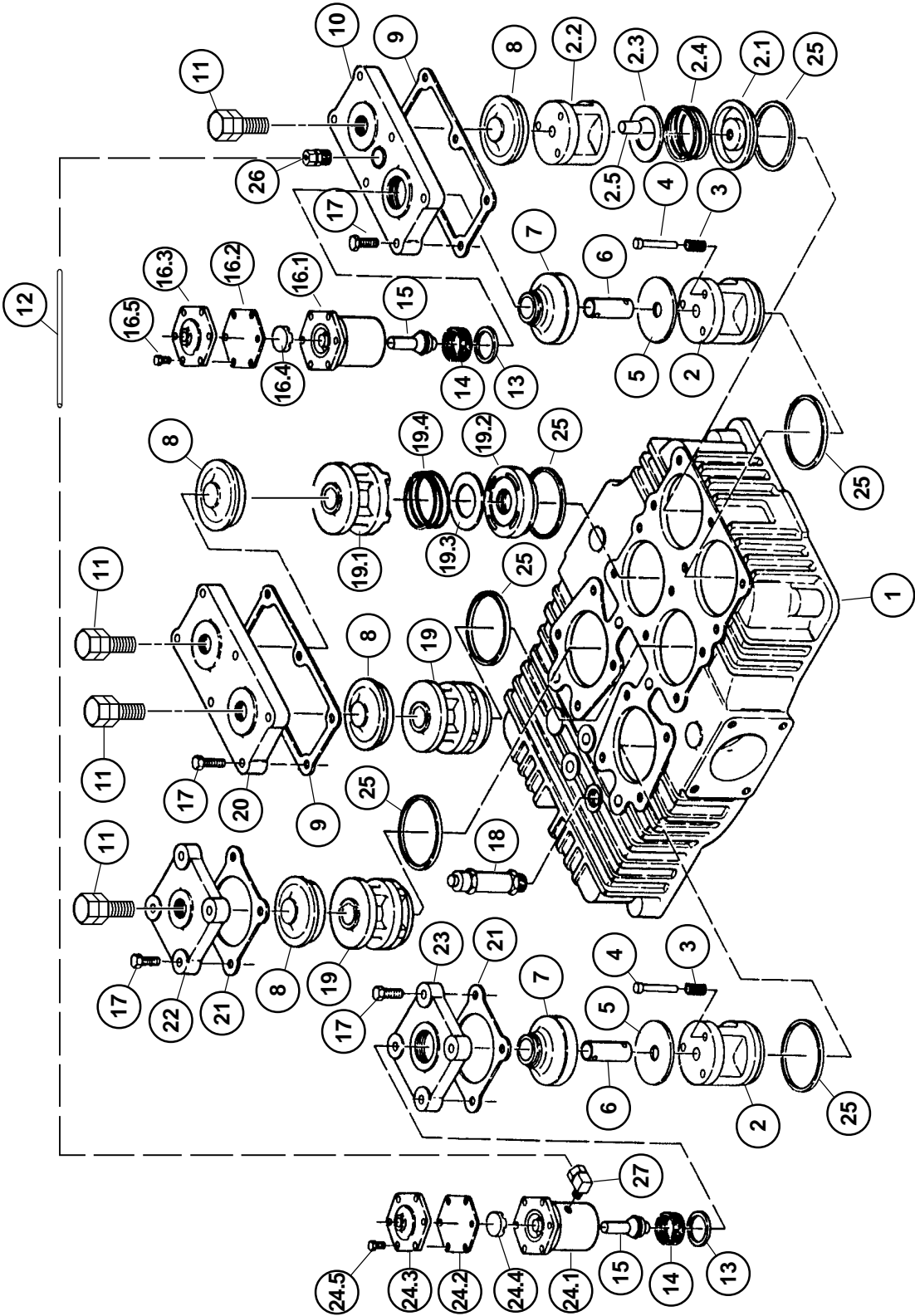

# \* LEFT HEAD ASSEMBLY 7382UU

(control versions L, LS, & LVD)

continued from page 16

Item Number	Qty.	Part Number	Description
<b>Parts for use with diester or phosphate ester synthetic based lubricants</b>			
16.2	1	1855S	diaphragm
24.2	1	1855S	diaphragm
<b>Maintenance Parts</b>			
1		<b>6671X</b>	<b>Replacement Suction Valve Assembly</b> includes suction valve assembly & valve gasket
2		<b>6671XU</b>	<b>Replacement Suction Valve Assembly</b> includes suction valve assembly, unloader pin springs, valve pins & valve gasket
3		<b>6670X01</b>	<b>Replacement Discharge Valve Assembly</b> includes discharge valve assembly & valve gasket
1		<b>7483X</b>	<b>Replacement Unloader Assembly</b> includes unloader assembly, unloader piston assembly, valve gasket & pipe plug
1		<b>8272X</b>	<b>Replacement Unloader Assembly</b> includes unloader piston assembly, unloader assembly, & valve gasket

\* As viewed facing the compressor from the bearing carrier side.

# \* RIGHT HEAD ASSEMBLY 7383UU

(control versions L, LS, & LVD)

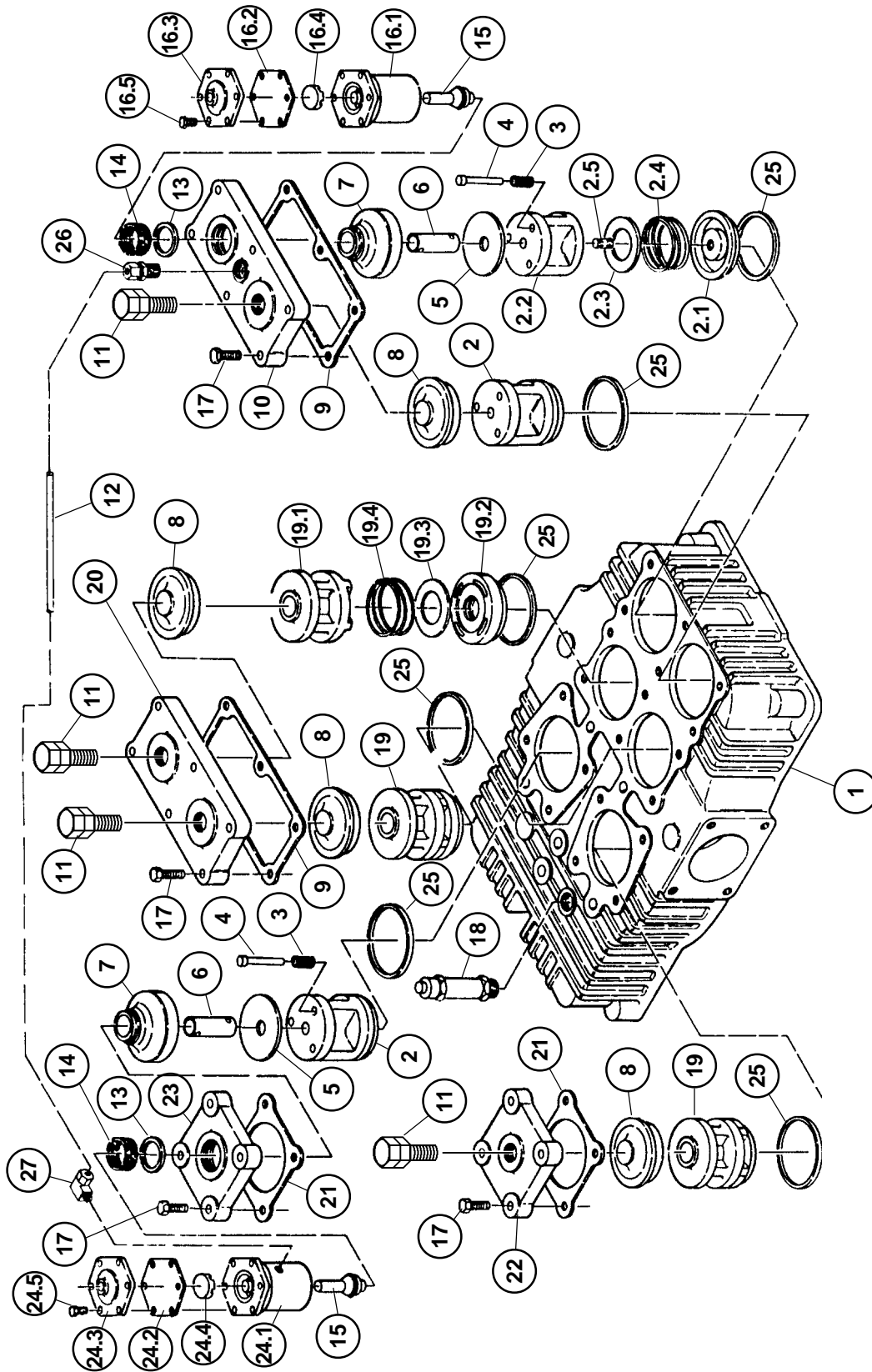

# \* RIGHT HEAD ASSEMBLY 7383UU

(control versions L, LS, & LVD)

Item Number	Qty.	Part Number	Description
1	1	7383	head
2	3	6671X1	suction valve assembly
2.1	1	6671	valve bumper
2.2	1	2015	suction valve seat
2.3	1	2036	valve disc
2.4	1	6909	valve spring
2.5	1	1849	stud
3	6	6910	valve spring
4	6	1857	valve pin
5	2	5729	valve platform
6	2	6912-001	unloader pin
7	2	6911	valve retainer
8	4	6668-1R	valve retainer
9	2	7398	valve cover gasket
10	1	7385	valve cover plate
‡ 11	4	114545-R15	hex screw and nut assembly, 3/4-16 unf x 1.50, grade 5 (screw @ 60 ft.-lbs. - nut @ 50 ft.-lbs.)
12	2 ft.	110515-025	copper tube, 1/4 o.d.
13	2	1556	gasket, valve
14	2	3008	holddown screw (@ 60 ft.-lbs.)
15	2	7532X	unloader piston assembly
16	1	40192	unloader assembly (@ 75 ft.-lbs.), (N.S.S.; order 8272X)
16.1	1	8272	unloader body
16.2	1	1855	diaphragm
16.3	1	1818B	diaphragm cover plate
16.4	1	5910	diaphragm disc
16.5	6	7499	hex. screw, 1/4-20 unc x .75, grade 2 (@ 72 in.-lbs.)
‡ 17	20	7480	hex. screw, 7/16-14 unc x 1.38, grade 5 (@ 50 ft.-lbs.)
18	1	2961-100	pressure relief valve
19	3	6670X001	discharge valve assembly
19.1	1	6670-001	valve bumper
19.2	1	5812-001	valve seat
19.3	1	2036	valve disc
19.4	1	6909	valve spring
20	1	7384	cover plate
21	2	2025	valve cover gasket
22	1	6666	cover plate
23	1	6908	cover plate
24	1	40055	unloader assembly (@ 75 ft.-lbs.) (N.S.S.; order 7483X)
24.1	1	7483	unloader body
24.2	1	1855	diaphragm
24.3	1	1818B	diaphragm cover plate
24.4	1	5910	diaphragm disc
24.5	6	7499	hex. screw, 1/4-20 unc x .75, grade 2 (@ 72 in.-lbs.)
25	6	2024	valve gasket
26	1	110594-005	tube fitting, male connector, 1/4 tube x 1/4 npt
27	1	1642	tube fitting, 90° male elbow, 1/4 tube x 1/8 npt

continued on page 22

\* As viewed facing the compressor from the bearing carrier side.

‡ Tighten and torque valve cover plate screws (item 17) before tightening valve clamp screws (item 11).

@ Indicates torque value (dry threads). Tighten multiple bolts, capscrews & hex nuts in a criss-cross or alternating pattern. Bring each fastener to the recommended torque specification in even increments.

N.S.S. = Not Sold Separate

# RIGHT HEAD ASSEMBLY 7383UU

(control versions L, LS, & LVD)

continued from page 19

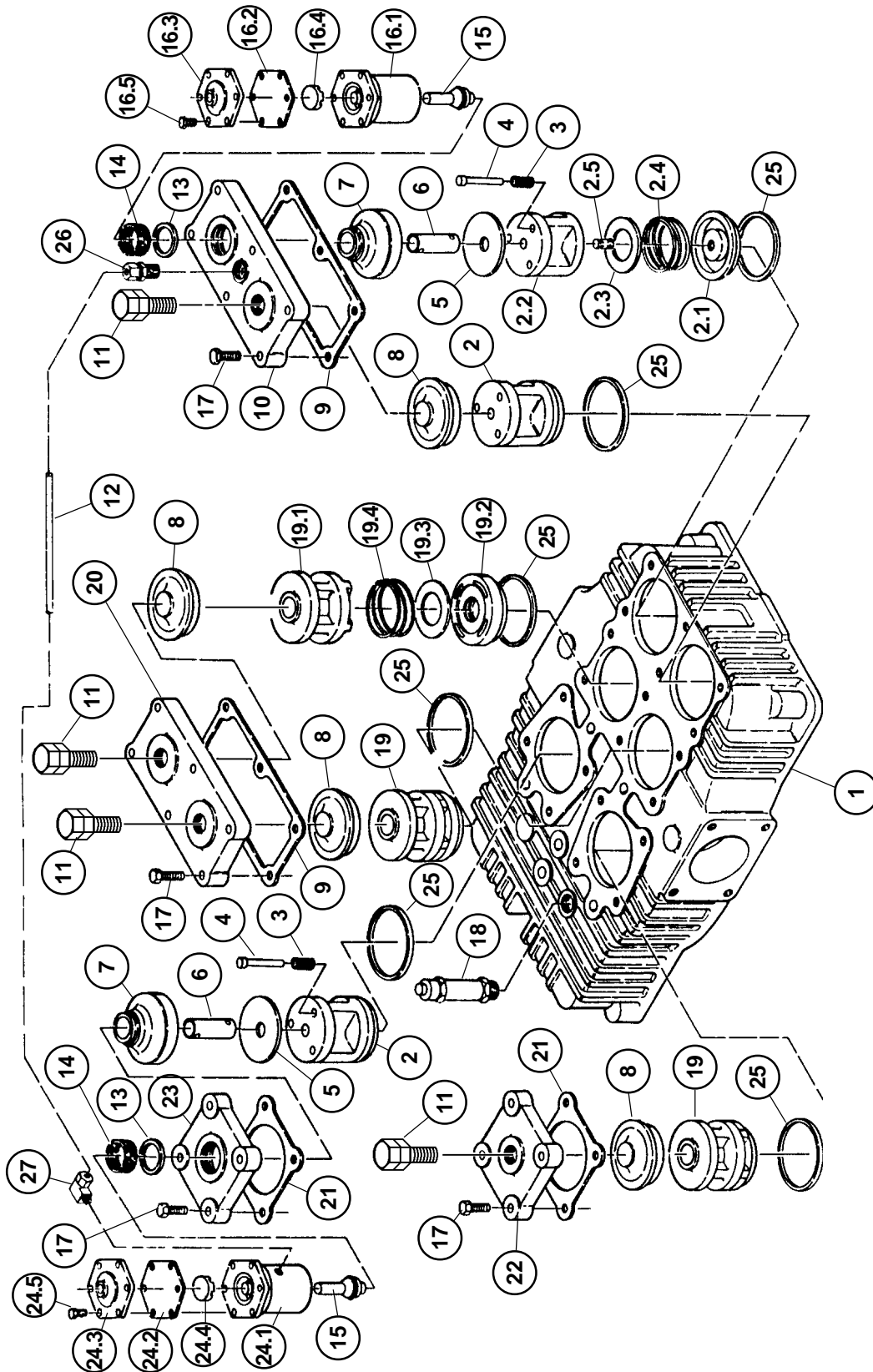

# \* RIGHT HEAD ASSEMBLY 7383UU

(control versions L, LS, & LVD)

continued from page 20

Item Number	Qty.	Part Number	Description
<b>Parts for use with diester or phosphate ester synthetic based lubricants</b>			
16.2	1	1855S	diaphragm
24.2	1	1855S	diaphragm
<b>Maintenance Parts</b>			
1		<b>6671X</b>	<b>Replacement Suction Valve Assembly</b> includes suction valve assembly & valve gasket
2		<b>6671XU</b>	<b>Replacement Suction Valve Assembly</b> includes suction valve assembly, unloader pin springs, valve pins & valve gasket
3		<b>6670X01</b>	<b>Replacement Discharge Valve Assembly</b> includes discharge valve assembly & valve gasket
1		<b>7483X</b>	<b>Replacement Unloader Assembly</b> includes unloader assembly, unloader piston assembly, valve gasket & pipe plug
1		<b>8272X</b>	<b>Replacement Unloader Assembly</b> includes unloader piston assembly, unloader assembly, & valve gasket

\* As viewed facing the compressor from the bearing carrier side.

# CONTROL GROUP 110861

(control version L)

Item Number	Qty.	Part Number	Description
1	1	110827-001	hydraulic unloader assembly
2	1	3324	tube fitting, 1/4 tube x 1/8 npt x 1/4 tube
3	3	1642	tube fitting, 90° male elbow, 1/4 tube x 1/8 npt
4	2	1665	tube fitting, male branch tee, 1/4 tube x 1/4 tube x 1/8 npt
5	7 ft.	110515-025	copper tube, 1/4 o.d.

### Maintenance Parts

**113225**

#### Hydraulic Unloader Repair Kit

includes diaphragm, stem assembly, inlet filter & fitting assembly, spring (0-200 PSI) and spring (201-250 PSI red color code)

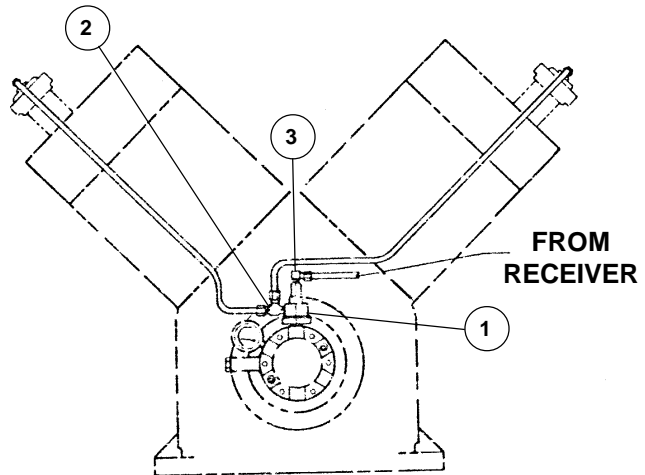
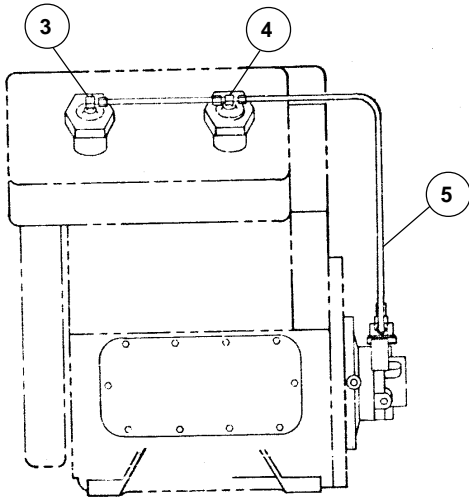

# CONTROL GROUP 116113-175 & 116113-998

(control version LS)

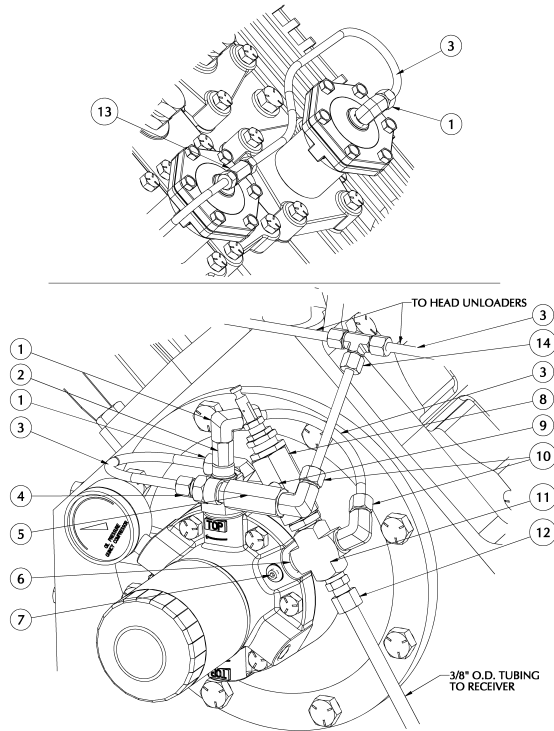

116113-175 "LS" CONTROL GROUP (175 PSI)			
ITEM	QTY	PART NUMBER	DESCRIPTION
1	4	1642	TUBE FITTING, ELBOW, 1/4" TUBE X 1/8" NPT
2	1	110827-001	HYDRAULIC UNLOADER ASSEMBLY, 0-200 PSI
3	8 FT	110515-025	COPPER TUBE, 1/4" O.D.
4	1	9353	TUBE FITTING, 1/4" TUBE X 1/4" FEMALE NPT
5	1	6194X2	CHECK VALVE
6	1	6317	STUD, MOUNTING
7	1	160047-J05	SET SCREW
8	1	113708-175	PILOT VALVE, TOGGLE, 165-175 PRESET
9	1	126015-001	NIPPLE, SCH40, GALV, 1/8" X CLOSE
10	2	2708	TUBE FITTING, ELBOW, 1/4" TUBE X 1/4" NPT
11	1	6150	CROSS, BRASS, 1/4"
12	1	2616	TUBE FITTING, 3/8" TUBE X 1/4" NPT
13	2	1665	TUBE FITTING, TEE, 1/4" TUBE X 1/8" NPT
14	1	4836	TUBE FITTING, TEE, 1/4" TUBE
MAINTENANCE PARTS			
		6317X1	MOUNTING STUD KIT INCLUDES ITEMS 6 & 7 (1 EACH)
		113225	HYDRAULIC UNLOADER REPAIR KIT INCLUDES DIAPHRAGM, STEM ASSEMBLY, INLET FILTER, FITTING ASSEMBLY, & SPRINGS.
		110827-003	HYDRAULIC UNLOADER ASSEMBLY 0-200 PSI USE WITH DIESTER OR PHOSPHATE ESTER SYNTHETIC BASED LUBRICANTS.

116113-998 "LS" CONTROL GROUP (60-200 PSI)			
ITEM	QTY	PART NUMBER	DESCRIPTION
1	4	1642	TUBE FITTING, ELBOW, 1/4" TUBE X 1/8" NPT
2	1	110827-001	HYDRAULIC UNLOADER ASSEMBLY, 0-200 PSI
3	8 FT	110515-025	COPPER TUBE, 1/4" O.D.
4	1	9353	TUBE FITTING, 1/4" TUBE X 1/4" FEMALE NPT
5	1	6194X2	CHECK VALVE
6	1	6317	STUD, MOUNTING
7	1	160047-J05	SET SCREW
8	1	113708-998	PILOT VALVE, TOGGLE, 60-200 CUSTOM SET
9	1	126015-001	NIPPLE, SCH40, GALV, 1/8" X CLOSE
10	2	2708	TUBE FITTING, ELBOW, 1/4" TUBE X 1/4" NPT
11	1	6150	CROSS, BRASS, 1/4"
12	1	2616	TUBE FITTING, 3/8" TUBE X 1/4" NPT
13	2	1665	TUBE FITTING, TEE, 1/4" TUBE X 1/8" NPT
14	1	4836	TUBE FITTING, TEE, 1/4" TUBE
MAINTENANCE PARTS			
		6317X1	MOUNTING STUD KIT INCLUDES ITEMS 6 & 7 (1 EACH)
		113225	HYDRAULIC UNLOADER REPAIR KIT INCLUDES DIAPHRAGM, STEM ASSEMBLY, INLET FILTER, FITTING ASSEMBLY, & SPRINGS.
		110827-003	HYDRAULIC UNLOADER ASSEMBLY 0-200 PSI USE WITH DIESTER OR PHOSPHATE ESTER SYNTHETIC BASED LUBRICANTS.

\* See page 29 for optional pilot valves that must be used with respective pressure ranges.

# CONTROL GROUP 116113-999

(control version LS)

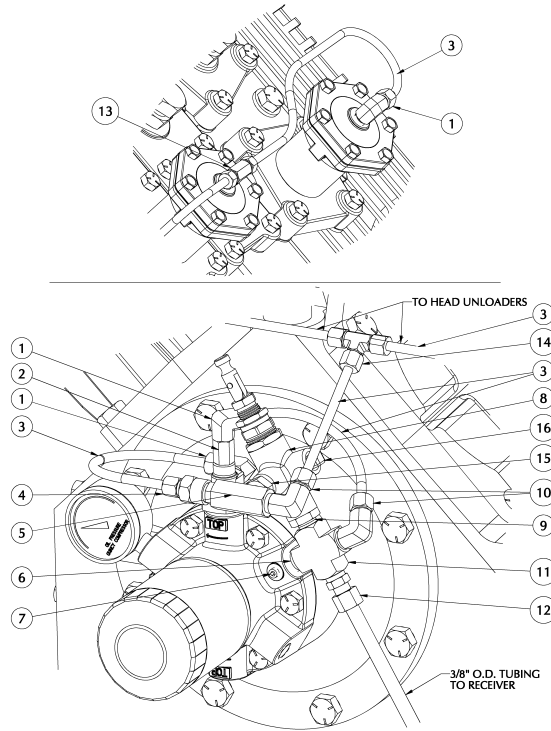

116113-999 "LS" CONTROL GROUP (201-250 PSI)			
ITEM	QTY	PART NUMBER	DESCRIPTION
1	4	1642	TUBE FITTING, ELBOW, 1/4" TUBE X 1/8" NPT
2	1	110827-002	HYDRAULIC UNLOADER ASSEMBLY, 201-500 PSI
3	8 FT	110515-025	COPPER TUBE, 1/4" O.D.
4	1	9353	TUBE FITTING, 1/4" TUBE X 1/4" FEMALE NPT
5	1	6194X2	CHECK VALVE
6	1	6317	STUD, MOUNTING
7	1	160047-J05	SET SCREW
8	1	110832-999	PILOT VALVE, TOGGLE, 201-400 CUSTOM SET
9	1	121032-3	NIPPLE, BRASS, 1/4" X CLOSE
10	2	2708	TUBE FITTING, ELBOW, 1/4" TUBE X 1/4" NPT
11	1	6150	CROSS, BRASS, 1/4"
12	1	2616	TUBE FITTING, 3/8" TUBE X 1/4" NPT
13	2	1665	TUBE FITTING, TEE, 1/4" TUBE X 1/8" NPT
14	1	4836	TUBE FITTING, TEE, 1/4" TUBE
15	1	116110	REDUCER, NIPPLE, HEX, 025 X 012
16	1	2719	PLUG, PIPE 1/4"
MAINTENANCE PARTS			
		6317X1	<b>MOUNTING STUD KIT</b> INCLUDES ITEMS 6 & 7 (1 EACH)
		113225	<b>HYDRAULIC UNLOADER REPAIR KIT</b> INCLUDES DIAPHRAGM, STEM ASSEMBLY, INLET FILTER, FITTING ASSEMBLY, & SPRINGS.
		110827-004	<b>HYDRAULIC UNLOADER ASSEMBLY 201-500 PSI</b> USE WITH DIESTER OR PHOSPHATE ESTER SYNTHETIC BASED LUBRICANTS.

\* See page 29 for optional pilot valves that must be used with respective pressure ranges.

# CONTROL GROUP 116116-165 & 116116-998

(control version LVD)

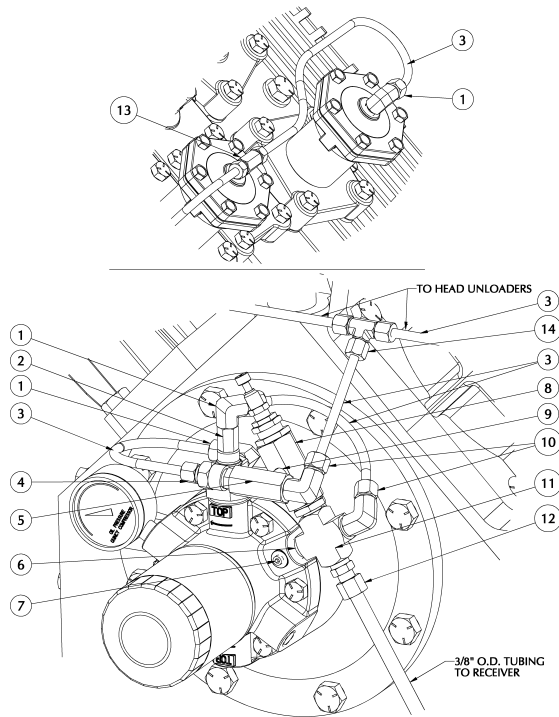

116116-165 "LVD" CONTROL GROUP (165 PSI)			
ITEM	QTY	PART NUMBER	DESCRIPTION
1	4	1642	TUBE FITTING, ELBOW, 1/4" TUBE X 1/8" NPT
2	1	110827-001	HYDRAULIC UNLOADER ASSEMBLY, 0-200 PSI
3	8 FT	110515-025	COPPER TUBE, 1/4" O.D.
4	1	9353	TUBE FITTING, 1/4" TUBE X 1/4" FEMALE NPT
5	1	6194X2	CHECK VALVE
6	1	6317	STUD, MOUNTING
7	1	160047-J05	SET SCREW
8	1	110998-165A	PILOT VALVE, TOGGLE, 155-165 PRESET
9	1	126015-001	NIPPLE, SCH40, GALV, 1/8" X CLOSE
10	2	2708	TUBE FITTING, ELBOW, 1/4" TUBE X 1/4" NPT
11	1	6150	CROSS, BRASS, 1/4"
12	1	2616	TUBE FITTING, 3/8" TUBE X 1/4" NPT
13	2	1665	TUBE FITTING, TEE, 1/4" TUBE X 1/8" NPT
14	1	4836	TUBE FITTING, TEE, 1/4" TUBE
MAINTENANCE PARTS			
		6317X1	<b>MOUNTING STUD KIT</b> INCLUDES ITEMS 6 & 7 (1 EACH)
		113225	<b>HYDRAULIC UNLOADER REPAIR KIT</b> INCLUDES DIAPHRAGM, STEM ASSEMBLY, INLET FILTER, FITTING ASSEMBLY, & SPRINGS.
		110827-003	<b>HYDRAULIC UNLOADER ASSEMBLY 0-200 PSI</b> USE WITH DIESTER OR PHOSPHATE ESTER SYNTHETIC BASED LUBRICANTS.

116116-998 "LVD" CONTROL GROUP (60-200 PSI)			
ITEM	QTY	PART NUMBER	DESCRIPTION
1	4	1642	TUBE FITTING, ELBOW, 1/4" TUBE X 1/8" NPT
2	1	110827-001	HYDRAULIC UNLOADER ASSEMBLY, 0-200 PSI
3	8 FT	110515-025	COPPER TUBE, 1/4" O.D.
4	1	9353	TUBE FITTING, 1/4" TUBE X 1/4" FEMALE NPT
5	1	6194X2	CHECK VALVE
6	1	6317	STUD, MOUNTING
7	1	160047-J05	SET SCREW
8	1	110998-998	PILOT VALVE, TOGGLE, 60-200 CUSTOM SET
9	1	126015-001	NIPPLE, SCH40, GALV, 1/8" X CLOSE
10	2	2708	TUBE FITTING, ELBOW, 1/4" TUBE X 1/4" NPT
11	1	6150	CROSS, BRASS, 1/4"
12	1	2616	TUBE FITTING, 3/8" TUBE X 1/4" NPT
13	2	1665	TUBE FITTING, TEE, 1/4" TUBE X 1/8" NPT
14	1	4836	TUBE FITTING, TEE, 1/4" TUBE
MAINTENANCE PARTS			
		6317X1	<b>MOUNTING STUD KIT</b> INCLUDES ITEMS 6 & 7 (1 EACH)
		113225	<b>HYDRAULIC UNLOADER REPAIR KIT</b> INCLUDES DIAPHRAGM, STEM ASSEMBLY, INLET FILTER, FITTING ASSEMBLY, & SPRINGS.
		110827-003	<b>HYDRAULIC UNLOADER ASSEMBLY 0-200 PSI</b> USE WITH DIESTER OR PHOSPHATE ESTER SYNTHETIC BASED LUBRICANTS.

\* See page 29 for optional pilot valves that must be used with respective pressure ranges.

# CONTROL GROUP 116116-999

(control version LVD)

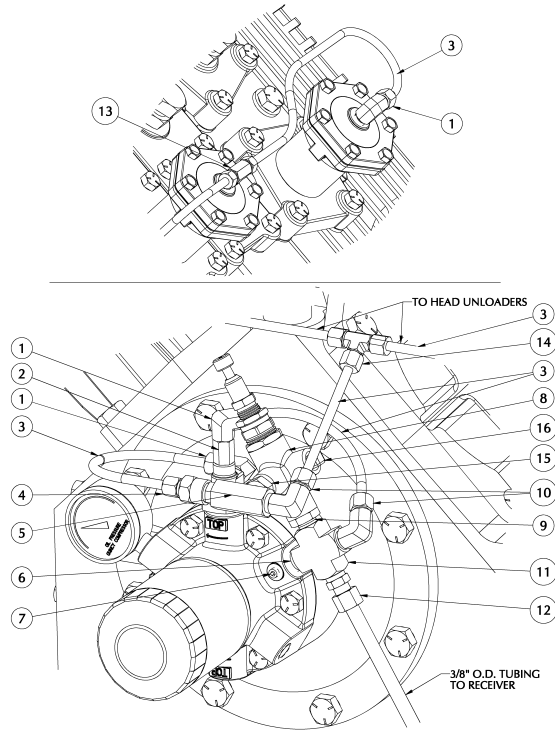

116116-999 "LVD" CONTROL GROUP (201-250 PSI)			
ITEM	QTY	PART NUMBER	DESCRIPTION
1	4	1642	TUBE FITTING, ELBOW, 1/4" TUBE X 1/8" NPT
2	1	110827-002	HYDRAULIC UNLOADER ASSEMBLY, 201-500 PSI
3	8 FT	110515-025	COPPER TUBE, 1/4" O.D.
4	1	9353	TUBE FITTING, 1/4" TUBE X 1/4" FEMALE NPT
5	1	6194X2	CHECK VALVE
6	1	6317	STUD, MOUNTING
7	1	160047-J05	SET SCREW
8	1	111423-001	PILOT VALVE, DUAL CTRL, 201-250 CUSTOM SET
9	1	121032-3	NIPPLE, BRASS, 1/4" X CLOSE
10	2	2708	TUBE FITTING, ELBOW, 1/4" TUBE X 1/4" NPT
11	1	6150	CROSS, BRASS, 1/4"
12	1	2616	TUBE FITTING, 3/8" TUBE X 1/4" NPT
13	2	1665	TUBE FITTING, TEE, 1/4" TUBE X 1/8" NPT
14	1	4836	TUBE FITTING, TEE, 1/4" TUBE
15	1	116110	REDUCER, NIPPLE, HEX, 025 X 012
16	1	2719	PLUG, PIPE 1/4"
MAINTENANCE PARTS			
		6317X1	<b>MOUNTING STUD KIT</b> INCLUDES ITEMS 6 & 7 (1 EACH)
		113225	<b>HYDRAULIC UNLOADER REPAIR KIT</b> INCLUDES DIAPHRAGM, STEM ASSEMBLY, INLET FILTER, FITTING ASSEMBLY, & SPRINGS.
		110827-004	<b>HYDRAULIC UNLOADER ASSEMBLY 201-500 PSI</b> USE WITH DIESTER OR PHOSPHATE ESTER SYNTHETIC BASED LUBRICANTS.

\* See page 29 for optional pilot valves that must be used with respective pressure ranges.

# SHROUD GROUP 110470-001

Item Number	Qty.	Part Number	Part Number	Description
1	1	113931-001		shroud assembly, RH
2	1	113932		bracket
3	2	7442		bracket
4	2	7441		bracket
5	1	113933		shroud support
6	8	122151		hex. screw, 1/4-20 unc x .75
7	4	22456		speed nut, 1/4-20 unc
8	1	113931-002		shroud assembly, LH

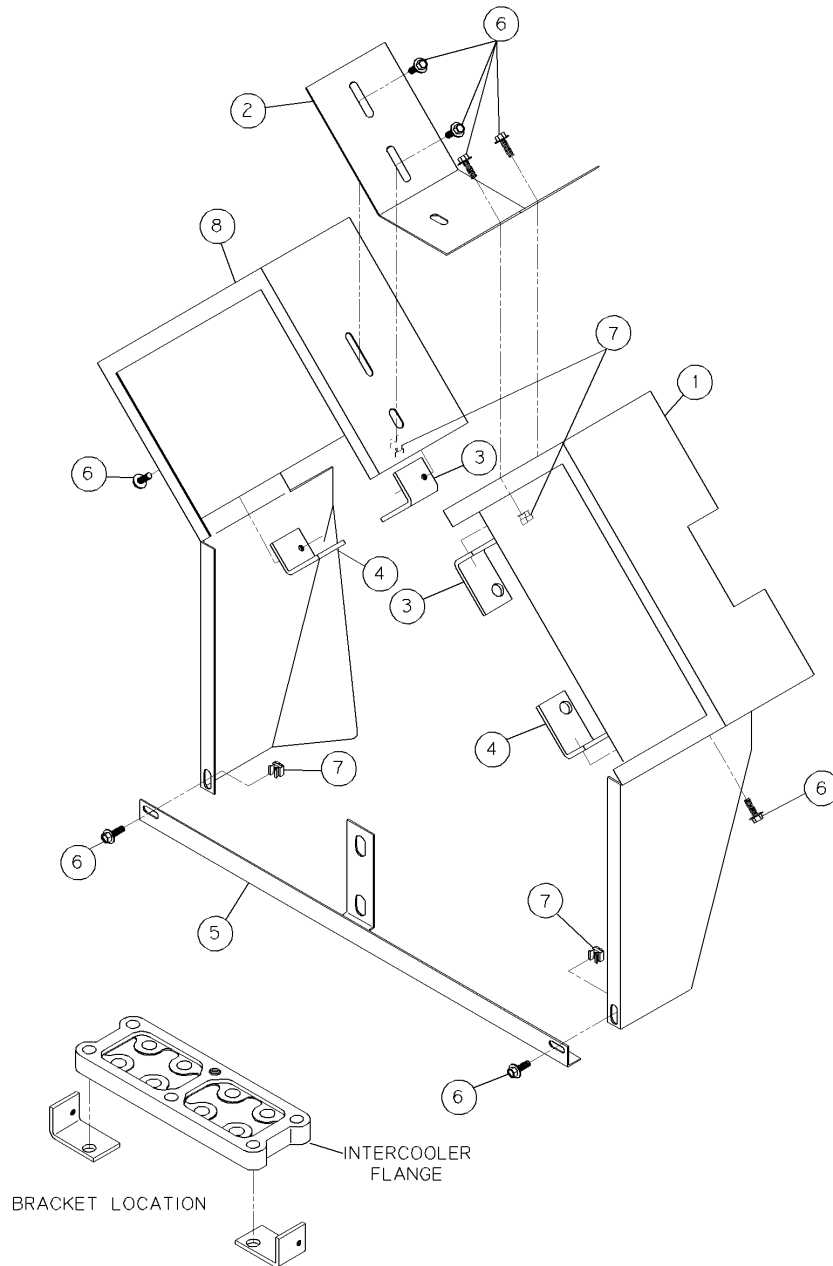

# PILOT VALVES

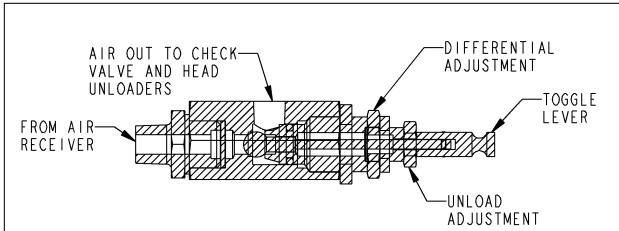

**113708 SERIES PILOT VALVE (CONTROL VERSION "LS")**

PART NUMBER	LOAD PSI	UNLOAD PSI
113708-175	165	175
113708-998	*	60-200 ADJUSTABLE

\* CUSTOMER TO SET, SEE DIFFERENTIAL SETTING CHART. ADDITIONAL FACTORY PRESET VALVES ARE AVAILABLE UPON REQUEST.

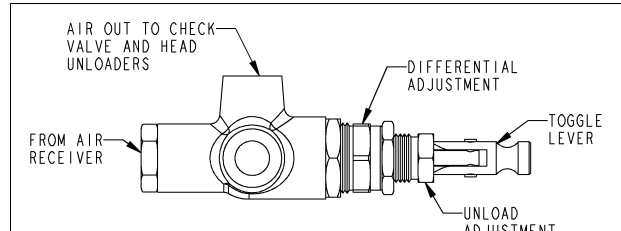

**110832 SERIES PILOT VALVE (CONTROL VERSION "LS")**

PART NUMBER	LOAD PSI	UNLOAD PSI
110832-999	*	201-250 ADJUSTABLE

\* CUSTOMER TO SET, SEE DIFFERENTIAL SETTING CHART. ADDITIONAL FACTORY PRESET VALVES ARE AVAILABLE UPON REQUEST.

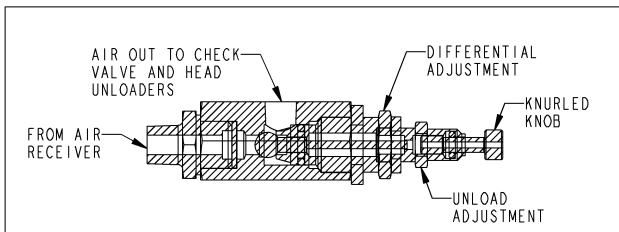

**110998 SERIES PILOT VALVE (CONTROL VERSION "LVD")**

PART NUMBER	LOAD PSI	UNLOAD PSI
110998-165A	155	165
110998-998	*	60-200 ADJUSTABLE

\* CUSTOMER TO SET, SEE DIFFERENTIAL SETTING CHART. ADDITIONAL FACTORY PRESET VALVES ARE AVAILABLE UPON REQUEST.

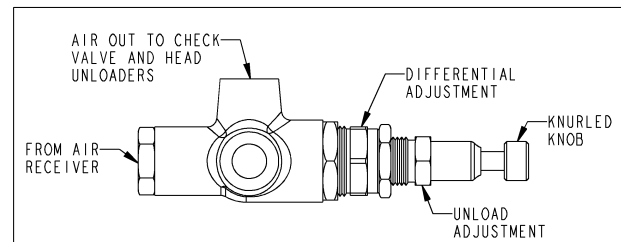

**111423-001 SERIES PILOT VALVE (CONTROL VERSION "LVD")**

PART NUMBER	LOAD PSI	UNLOAD PSI
111423-001	*	201-250 ADJUSTABLE

\* CUSTOMER TO SET, SEE DIFFERENTIAL SETTING CHART. ADDITIONAL FACTORY PRESET VALVES ARE AVAILABLE UPON REQUEST.

### DIFFERENTIAL SETTING CHART

APPLIES TO 113708 AND 110998 SERIES PILOT VALVES ONLY.

UNLOAD (PSI)	MIN. DIF. (PSI)	MAX. DIF. (PSI)
60	3	10
100	4	20
150	5	30
175	5	45

### PILOT VALVE REPAIR KIT 110832-051

FOR 110832 AND 111423 SERIES PILOT VALVES ONLY

**110832-051 INCLUDES SCREENS, FILTER, O-RING, BALL, RIVET PIN, AND DISCS AND O-RING FOR 6194X SERIES CHECK VALVES.**

**CUSTOMER MUST ORDER SPRING WHEN ORDERING REPAIR KIT (SEE BELOW)**

PART #	QTY	DESCRIPTION
110832-054	1	REPLACEMENT SPRING, PILOT VALVE, 201-250 PSI (GREEN)

### DIFFERENTIAL SETTING CHART

APPLIES TO 110832 AND 111423 SERIES PILOT VALVES ONLY.

SPRING NUMBER	UNLOAD (PSI)	MIN. DIF. (PSI)	MAX. DIF. (PSI)
110832-054	201	5	25
"	250	10	30

## WARNING !

**Not all pilots are for use with all compressor systems. Make sure that the pilot you order is set within the safe operating limits of your compressor. Failure to heed this warning could result in an explosion.**

# SUCTION VALVE UNLOADER ASSEMBLIES

## Description

The Quincy suction valve unloader assembly consists of unloading arrangements on the suction valves, having a plunger to contact the suction valve disc and an unloader pilot valve (part no.s 110998-\*\*\* & 113708-\*\*\*) to automatically regulate the passing of receiver pressure to the unloading arrangement.

## Application

Suction valve unloader assemblies are recommended for use on Quincy compressors where the compressor is to run continuously and a constant pressure is to be maintained. The purpose is to automatically unseat the suction valve of the compressor when the air supply is greater than the demand.

## Operation

Unloading occurs when receiver pressure is sufficient to overcome pilot valve spring pressure. The check ball is then unseated, allowing receiver pressure to pass to the unloading arrangements. The compressor will run unloaded until the receiver pressure drops to a predetermined level. At this time, the action of the ball is reversed, shutting off receiver pressure to the unloader arrangement and venting the unloader to atmosphere. This allows the compressor to load. The drive, either electric motor or combustion engine, runs continuously and must be started and stopped manually.

Pilot valve 110998-\*\*\* can be locked out, for models equipped with dual control, to provide automatic start/stop operation. The knurled knob at the top of the pilot can be turned clockwise, until it stops, to lock it out. A pressure switch is required to stop the motor. Failure to use a pressure switch, with the pilot valve locked out, could result in unsafe conditions.

**WARNING !**

A pressure switch must be incorporated whenever pilot valve 110998-\*\*\* is employed as part of the control system.

The compressor will operate in the continuous run mode if the knurled knob is turned counterclockwise until it stops.

## Installation

The pilot valve is to be connected to the air receiver using a minimum of 3/8" o.d. copper tube. Compressors in the field, not equipped with a suction valve unloader assembly, can be converted to constant

speed. Consult your local Quincy Compressor Distributor for assistance with conversion procedures.

## Service

Periodically check the filter & screens in the inlet of the pilot valve to make sure they are free of obstructions. If they become clogged, remove and clean or replace. Inspect the "o"ring located in the opposite end of the pilot valve body for wear or damage; replace if necessary.

## Adjustment

The unloading pressure is adjustable and is regulated by turning the hex nut (marked "unload adj." in cross sectional illustrations of pilot valves). Turn the hex nut clockwise to increase and counterclockwise to decrease the unloading pressure.

The differential (difference between unloading and loading pressure) is set by turning the hex nut (marked "differential adj." in the cross sectional illustrations of the pilot valves). Increase the differential pressure by turning the hex nut clockwise - decrease by turning counterclockwise. Tighten the locknuts after adjustment.

# CHECK VALVE ASSEMBLIES

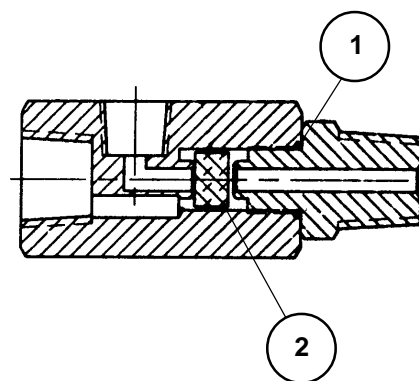

Check Valve Assembly Replacement Parts			
Item #	Qty.	Part Number	Description
		<b>6194X2</b>	<b>Check Valve Assembly</b>
1	1	123157-010	"o"ring
2	1	6196-002	disc
		<b>6194X3</b>	<b>Check Valve Assembly</b>
		<i>(for use with diester or phosphate ester synthetic lubricants)</i>	
1	1	22749-010	"o"ring
2	1	6196-003	disc

Head Kit K5120A			
Item #	Qty.	Part Number	Description
12		2036	valve disc
12		6909	valve spring
12		2024	valve gasket
4		7398	valve cover gasket
4		2025	valve cover gasket
4		1556	gasket, valve
4		1855	diaphragm
2		7403	gasket, cylinder to head
2		110377E200	air filter element
2		5860	gasket, intercooler to head

Overhaul Kit K5120B			
Item #	Qty.	Part Number	Description
2		110377E200	air filter element
1		110775-001	"o" ring kit
12		2036	valve disc
4		6656PR	connecting rod inserts (1 pair)
12		6909	valve spring
1		7435	gasket set
2		7527	ring set
2		8168	ring set
1		8966	adjustment seal

Recommended Spare Parts			
Item #	Qty.	Part Number	Description
2		1855	diaphragm
2		1855S	diaphragm
2		6671X	replacement suction valve assy.
2		6670X01	valve assembly
2		6656PR	inserts, connecting rod
1		110822	oil pressure gauge
1		160079-002	oil pump repair kit
1		160079-003	oil pump repair kit, diester
1		110832-051	pilot repair kit
1		7435	gasket set
2		110377E200	air filter element
1		113225	hydraulic unloader repair kit

Basic Compressor Repair Kit 110823-510			
Item #	Qty.	Part Number	Description
2		110190-004	piston pin
2		110377E200	air filter element
1		110775-001	"o" ring kit
4		110799-010	needle bearing
1		110814	oil filter
12		2036	valve disc
1		3720	bearing cup
1		40775	bearing cone
1		4357	bearing cup
2		6443SR	replacement con rod bushing
1		6651	bearing cone
4		6656PR	connecting rod inserts
12		6909	valve spring
1		7435	gasket set
2		7527	Piston Ring Set, LP
2		8168	Piston Ring Set, HP
2		8647	piston pin
4		8648	retaining ring

V.I.P. Kit 110516-510			
Item #	Qty.	Part Number	Description
1		110822	oil pressure gauge
4		1855	diaphragm
12		1857	valve pin
12		2036	valve disc
2		6283	hydraulic unloader filter
12		6909	valve spring
12		6910	valve spring
1		7435	gasket set

Piston Pin Kit K5120F			
Item #	Qty.	Part Number	Description
2		110190-004	piston pin
2		8647	piston pin
2		6443SR	Replacement Con-Rod Bushing
4		110799-010	needle bearing
8		8648	retaining ring

Gasket Set 7435			
Item #	Qty.	Part Number	Description
4		1556	gasket, valve
12		2024	gasket, valve
4		2025	gasket, valve cover
1		5494	gasket, bearing carrier
2		5827	gasket, cylinder to crankcase
5		5828	gasket, companion flange
2		5860	gasket, intercooler to head
2		6678	gasket, inspection plate
1		6679	gasket, oil inlet bracket
4		7398	gasket, valve cover
2		7403	gasket, cylinder to head

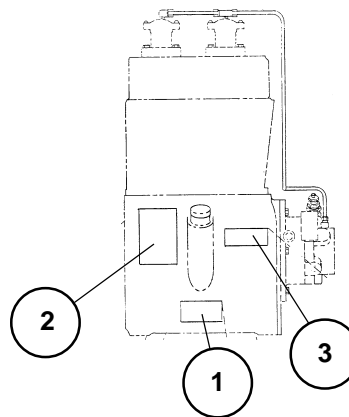

Decals			
Item #	Qty.	Part Number	Description
1	1	110831	serial number & nameplate
2	1	* 127889-A	decal, CAUTION!/manual/ "Failure to follow..."
3	1	* 127889-B	decal, DANGER! / "Air used for breathing..."

\* Not sold separate; order 127889.

# TYPICAL UNIT REPAIR PARTS LIST

The parts listed here are for standard QR 5120 units and may or may not be applicable to specially built units. Check with your local authorized Quincy distributor for parts that can be used for custom built units. Make sure the components you order are rated within the safe operating limits of your system. If you are doubtful about which components to order, contact your local Quincy distributor.

(QR 5120 simplex - horizontal tank - electric motor)

Qty	Part Number	Part Number	Part Number	Description
	<b>120 gal.</b>	<b>200 gal.</b>		
1	113271-200	113273-200		tank
1	113279	<i>113283</i>		top plate
1	111136-050	111136-050		tank drain valve
1	111136-100	111136-100		service valve
1	110514-300	110514-300		pressure gauge
*1	110512-003	110512-003		pressure switch (135-175 PSI)
1	110513-200	110513-200		pressure relief valve (200 PSI; in tank)
1	121918-141	121918-141		discharge tube
2	111265	111265		ferrule/sleeve
	<b>25 h.p.</b>			
3	<i>110258B120</i>			drive belt
1	<i>8310</i>			motor pulley
1	<i>8461</i>			motor pulley bushing
1	<i>111978K002</i>			belt guard assembly
	<b>200v, 3Ø</b>	<b>230/460v, 3Ø</b>		
1	<i>40659</i>	<i>7360</i>		25 h.p. motor (ODP)

(QR 5120 duplex - horizontal tank - electric motor)

Qty	Part Number	Part Number	Part Number	Description
	<b>200 gal.</b>	<b>240 gal.</b>		
1	113468-200	113470-200		tank
2	<i>113283</i>	<i>113283</i>		top plate
1	111136-050	111136-050		tank drain valve
1	111136-100	111136-100		service valve
1	110514-300	110514-300		pressure gauge
*2	110512-003	110512-003		pressure switch (135-175 PSI)
1	110513-200	110513-200		pressure relief valve (200 PSI; in tank)
2	121918-141	121918-141		discharge tube
4	111265	111265		ferrule/sleeve
	<b>25 h.p.</b>			
6	<i>110258B120</i>			drive belt
2	<i>8310</i>			motor pulley
2	<i>8461</i>			motor pulley bushing
2	<i>111978K002</i>			belt guard assembly
	<b>200v, 3Ø</b>	<b>230/460v, 3Ø</b>		
2	<i>40659</i>	<i>7360</i>		25 h.p. motor (ODP)

Part numbers shown in italics apply to tank mounted units and base mounted units.

\* 2298-175 pressure switch on base mounted units

## **QUINCY COMPRESSOR**

### **STANDARD TERMS AND CONDITIONS**

**LEGAL EFFECT:** Except as expressly otherwise agreed to in writing by an authorized representative of Seller, the following terms and conditions shall apply to and form a part of this order and any additional and/or different terms of Buyer's purchase order or other form of acceptance are rejected in advance and shall not become a part of this order.

The rights of Buyer hereunder shall be neither assignable nor transferable except with the written consent of Seller.

This order may not be canceled or altered except with the written consent of Seller and upon terms which will indemnify Seller against all loss occasioned thereby. All additional costs incurred by Seller due to changes in design or specifications, modification of this order or revision of product must be paid for by Buyer.

In addition to the rights and remedies conferred upon Seller by this order, Seller shall have all rights and remedies conferred at law and in equity and shall not be required to proceed with the performance of this order if Buyer is in default in the performance of such order or of any other contract or order with seller.

**TERMS OF PAYMENT:** Unless otherwise specified in the order acknowledgment, the terms of payment shall be 1% 15, net forty-five (45) days after shipment. These terms shall apply to partial as well as complete shipments. If any proceeding be initiated by or against Buyer under any bankruptcy or insolvency law, or in the judgment of Seller the financial condition of Buyer, at the time the equipment is ready for shipment, does not justify the terms of payment specified, Seller reserves the right to require full payment in cash prior to making shipment. If such payment is not received within fifteen (15) days after notification of readiness for shipment, Seller may cancel the order as to any unshipped item and require payment of its reasonable cancellation charges.

If Buyer delays shipment, payments based on date of shipment shall become due as of the date when ready for shipment. If Buyer delays completion of manufacture, Seller may elect to require payment according to percentage of completion. Equipment held for Buyer shall be at Buyer's risk and storage charges may be applied at the discretion of Seller.

Accounts past due shall bear interest at the highest rate lawful to contract for but if there is no limit set by law, such interest shall be eighteen percent (18%). Buyer shall pay all cost and expenses, including reasonable attorney's fees, incurred in collecting the same, and no claim, except claims within Seller's warranty of material or workmanship, as stated below, will be recognized unless delivered in writing to Seller within thirty (30) days after date of shipment.

**TAXES:** All prices exclude present and future sales, use, occupation, license, excise, and other taxes in respect of manufacture, sales or delivery, all of which shall be paid by Buyer unless included in the purchase price at the proper rate or a proper exemption certificate is furnished.

**ACCEPTANCE:** All offers to purchase, quotations and contracts of sales are subject to final acceptance by an authorized representative at Seller's plant.

**DELIVERY:** Except as otherwise specified in this quotation, delivery will be F. O. B. point of shipment. In the absence of exact shipping instruction, Seller will use its discretion regarding best means of insured shipment. No liability will be accepted by Seller for so doing. All transportation charges are at Buyer's expense. Time of delivery is an estimate only and is based upon the receipt of all information and necessary approvals. The shipping schedule shall not be construed to limit seller in making commitments for materials or in fabricating articles under this order in accordance with Seller's normal and reasonable production schedules.

Seller shall in no event be liable for delays caused by fires, acts of God, strikes, labor difficulties, acts of governmental or military authorities, delays in transportation or procuring materials, or causes of any kind beyond Seller's control. No provision for liquidated damages for any cause shall apply under this order. Buyer shall accept delivery within thirty (30) days after receipt of notification of readiness for shipment. Claims for shortages will be deemed to have been waived if not made in writing with ten (10) days after the receipt of the material in respect of which any such shortage is claimed. Seller is not responsible for loss or damage in transit after having received "In Good Order" receipt from the carrier. All claims for loss or damage in transit should be made to the carrier.

**TITLE & LIEN RIGHTS:** The equipment shall remain personal property, regardless of how affixed to any realty or structure. Until the price (including any notes given therefore) of the equipment has been fully paid in cash, Seller shall, in the event of Buyer's default, have the right to repossess such equipment.

**PATENT INFRINGEMENT:** If properly notified and given an opportunity to do so with friendly assistance, Seller will defend Buyer and the ultimate user of the equipment from any actual or alleged infringement of any published United States patent by the equipment or any part thereof furnished pursuant hereto (other than parts of special design, construction, or manufacture specified by and originating with Buyer), and will pay all damages and costs awarded by competent court in any suit thus defended or of which it may have had notice and opportunity to defend as aforesaid.

**STANDARD WARRANTY:** Seller warrants that products of its own manufacture will be free from defects in workmanship and materials under normal use and service for the period specified in the product instruction manual. Warranty for service parts will be Ninety (90) days from date of factory shipment. Electric Motors, gasoline and diesel engines, electrical apparatus and all other accessories, components and parts not manufactured by Seller are warranted only to the extent of the original manufacturer's warranty.

Notice of the alleged defect must be given to the Seller, in writing with all identifying details including serial number, type of equipment and date of purchase within thirty (30) days of the discovery of the same during the warranty period.

Seller's sole obligation on this warranty shall be, at its option, to repair or replace or refund the purchase price of any product or part thereof which proves to be defective. If requested by Seller, such product or part thereof must be promptly returned to seller, freight prepaid, for inspection.

Seller warrants repaired or replaced parts of its own manufacture against defects in materials and workmanship under normal use and service for ninety (90) days or for the remainder of the warranty on the product being repaired.

This warranty shall not apply and Seller shall not be responsible or liable for:

- (a) Consequential, collateral or special losses or damages;
- (b) Equipment conditions caused by fair wear and tear, abnormal conditions of use, accident, neglect or misuse of equipment, improper storage or damage resulting during shipping;
- (c) Deviation from operating instructions, specifications or other special terms of sale;
- (d) Labor charges, loss or damage resulting from improper operation, maintenance or repairs made by person(s) other than Seller or Seller's authorized service station.

In no event shall Seller be liable for any claims whether arising from breach of contract or warranty or claims of negligence or negligent manufacture in excess of the purchase price.

**THIS WARRANTY IS THE SOLE WARRANTY OF SELLERS AND ANY OTHER WARRANTIES, WHETHER EXPRESSOR IMPLIED IN LAW OR IMPLIED IN FACT, INCLUDING ANY WARRANTIES OF MERCHANTABILITY AND FITNESS FOR PARTICULAR USE ARE HEREBY SPECIFICALLY EXCLUDED.**

**LIABILITY LIMITATIONS:** Under no circumstances shall the Seller have any liability for liquidated damages or for collateral, consequential or special damages or for loss of profits, or for actual losses or for loss of production or progress of construction, whether resulting from delays in delivery or performance, breach of warranty, negligent manufacture or otherwise.

**ENVIROMENTAL AND OSHA REQUIREMENTS:** At the time of shipment of the equipment from the factory, Quincy Compressor / Ortman Fluid Power will comply with the various Federal, State and local laws and regulations concerning occupational health and safety and pollution. However, in the installation and operation of the equipment and other matters over which the seller has no control, the Seller assumes no responsibility for compliance with those laws and regulations, whether by the way of indemnity, warranty or otherwise.

June 30, 2003



an EnPro Industries company

**Reciprocating / Systems:** 217.222.7700  
**Air Master** 217.277.0270  
**E-mail:** info@quincycompressor.com  
**Website:** quincycompressor.com  
quincyairmaster.com



© 2006 Quincy Compressor, an EnPro Industries company  
All Rights Reserved. Litho in U.S.A.